









V-TONE DP-88

Instrukcja obsługi / User Manual

Spis treści

| | |
|--|----|
| Bezpieczeństwo użytkowania | 2 |
| Konserwacja | 2 |
| Budowa..... | 3 |
| Obsługa | 4 |
| Tabela tonów | 8 |
| Tabela rytmów | 11 |
| Tabela utworów demonstracyjnych | 13 |
| Informacja o zużytych sprzęcie elektrycznym i elektronicznym | 14 |

Bezpieczeństwo użytkowania

| | |
|---|--|
|  | Przed użyciem prosimy o szczegółowe zapoznanie się z instrukcją obsługi. Prosimy również o zachowanie jej na przyszłość. Instrukcja zawiera zasady bezpiecznego korzystania z urządzenia. |
|  | Po otrzymaniu produktu należy go rozpakować i sprawdzić, czy produkt jest kompletny i czy podczas transportu nie powstały żadne uszkodzenia. W przypadku uszkodzeń powstałych podczas transportu, prosimy nie używać produktu i niezwłocznie skontaktować się ze sprzedawcą lub producentem. |
|  | UWAGA! URZĄDZENIA NIE WOLNO WYRZUCAĆ DO ODPADÓW DOMOWYCH. To oznaczenie oznacza, że produkt nie może być wyrzucany razem z odpadami domowymi w całej UE. W celu zapobiegnięcia potencjalnym szkodom dla środowiska lub zdrowia, zużyty produkt należy poddać recyklingowi. Zgodnie z obowiązującym prawem, nie nadający się do użycia sprzęt elektryczny i elektroniczny należy zbierać osobno, w specjalnie do tego celu wyznaczonych punktach zbierania zużytego sprzętu, celem ich przetworzenia i ponownego wykorzystania na podstawie obowiązujących norm ochrony środowiska. |
|  | Produkt opisany w tej instrukcji jest zgodny z dyrektywami europejskimi, dlatego jest oznaczony znakiem CE. |
|  | Przed użyciem upewnij się, że obudowa nie jest uszkodzona. |
|  | Zapewnij minimum 1 m dystansu pomiędzy urządzeniem a materiałami łatwopalnymi. |
|  | Urządzenie pracuje na zasilaniu oznaczonym na obudowie - nie należy podłączać do prądu o innych parametrach. Odłączenie produktu od zasilania odbywa się poprzez pociągnięcie za wtyczkę przewodu zasilającego - nie ciągnąć bezpośrednio za przewód zasilający! Odłącz urządzenie z zasilania przed konserwacją. W razie stwierdzenia uszkodzenia przewodu zasilającego - nie używaj go! Nie wolno przechowywać i korzystać z urządzenia w pobliżu źródeł ognia! |
|  | Urządzenie do użytku wewnętrznego, nie narażać na długotrwałe działanie wilgoci. Nie należy narażać produktu na bezpośrednie działanie słońca lub innych urządzeń oświetleniowych. Nie należy korzystać z urządzenia na podłożu narażonym na wibracje. Nie wolno narażać urządzenia na pracę w wysokich temperaturach! W razie wystąpienia zakłóceń w pracy urządzenia, natychmiast odłącz je od źródła zasilania! |

Konserwacja

1. Urządzenie może użytkować tylko wykwalifikowany personel, szkody spowodowane użytkowaniem niezgodnym z przeznaczeniem lub próbą samodzielnej naprawy nie podlegają gwarancji. Wewnątrz opakowania nie ma żadnych części serwisowych, naprawy mogą być wykonywane wyłącznie przez autoryzowany punkt serwisowy.
2. Nie pozwól, aby urządzenie weszło w kontakt z olejem, tłuszczem lub jakimkolwiek podobnym płynem.
3. Regularne czyszczenie umożliwia długotrwałe użytkowanie oraz pozwala na zachowanie odpowiedniej jakości pracy. Do czyszczenia urządzenia używaj miękkiej szmatki.

Budowa

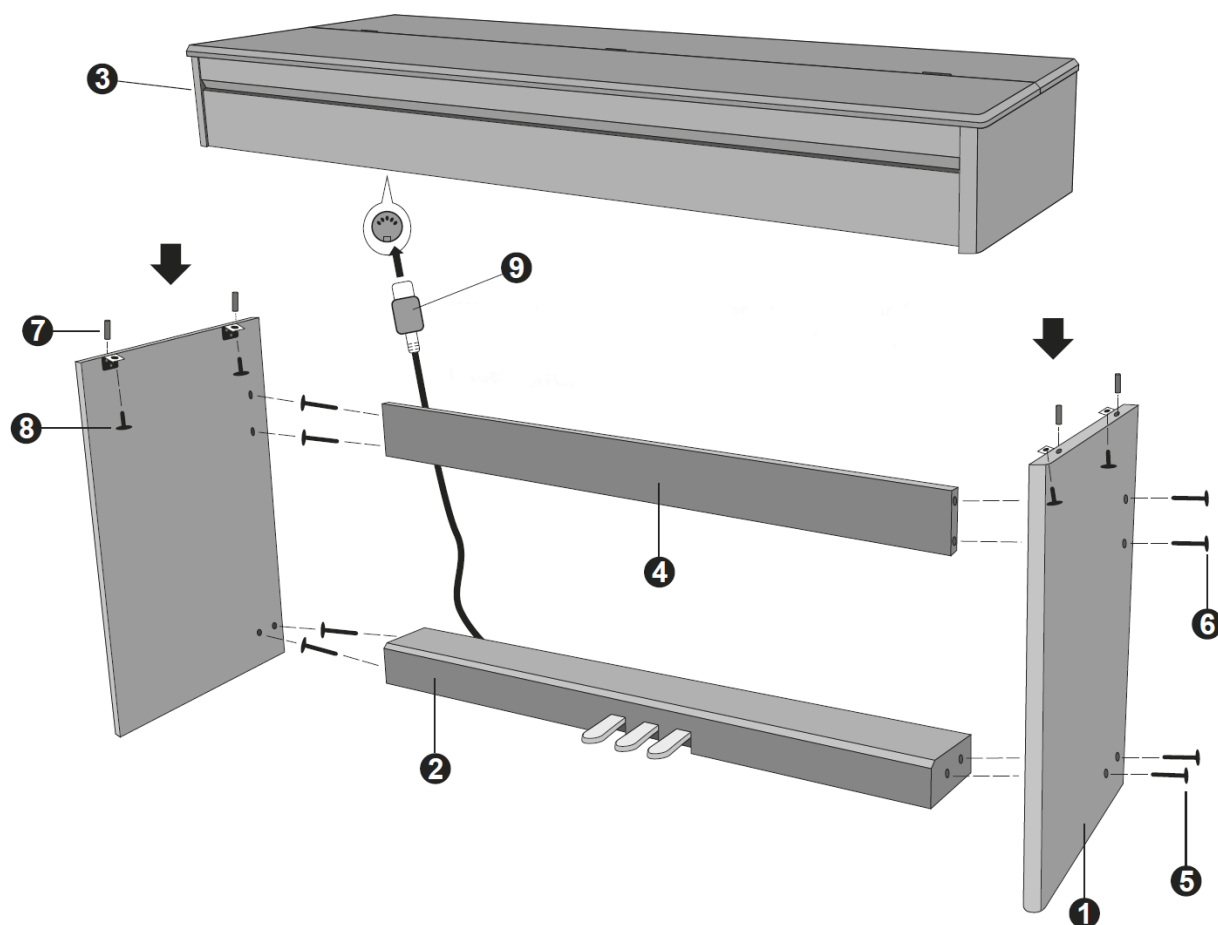

1. Lewy i prawy wspornik.
2. Belka poprzeczna pedałów.
3. Korpus.
4. Płyta tylna.
5. Cztery śruby M6x50.

6. Cztery śruby M4x50.
7. Cztery kołki 40.
8. Cztery śruby M6x18.
9. Przewód z wtyczką pedałów.

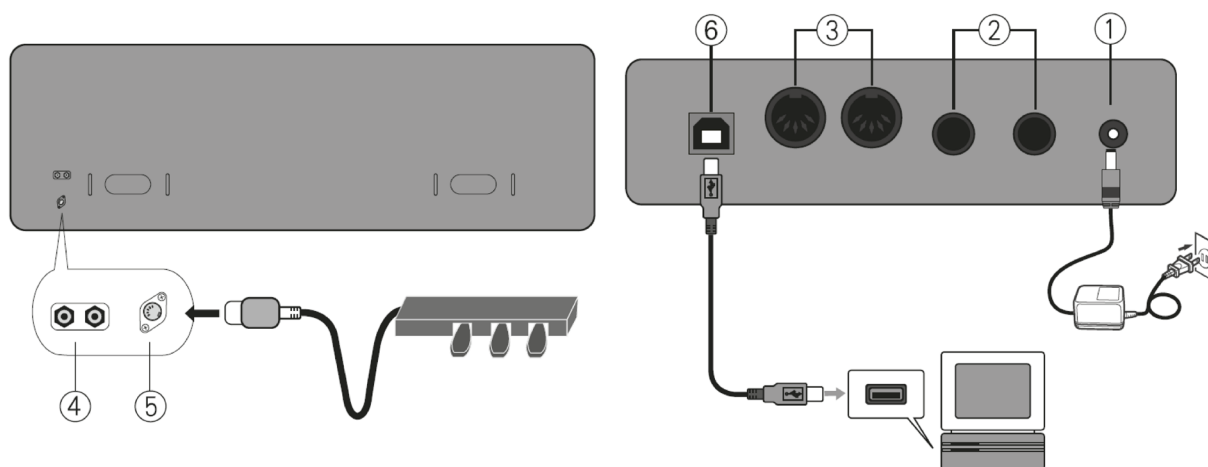

1. Wejście zasilania DC.
2. Wejście / wyjście audio.
3. Wejście / wyjście MIDI.

4. Dwa wyjścia słuchawkowe.
5. Wejście pedałów.
6. Gniazdo USB-B.

Obsługa

Włączanie/wyłączanie urządzenia

1. Umieścić wtyczkę przewodu zasilającego w źródle zasilania, zachowując zasady bezpieczeństwa. Wtyczkę DC umieścić w gnieździe zasilania urządzenia.
2. Włączyć / wyłączyć urządzenie za pomocą przycisku „POWER”.

Kontrola głośności

Użyć potencjometru regulacji głośności „VOLUME”, aby zwiększyć lub zmniejszyć głośność pianina.

Wybór tonu

1. Nacisnąć przycisk „TONE”, aby wejść w tryb wyboru tonu.
2. Wybrać ton za pomocą obracania potencjometru „NUMERICAL SEL” - kod i nazwa tonu pojawią się na wyświetlaczu.

Wybór rytmu

1. Nacisnąć przycisk „RHYTHM”, aby wejść w tryb wyboru rytmu.
2. Wybrać rytm za pomocą obracania potencjometru „NUMERICAL SEL” - kod i nazwa rytmu pojawią się na wyświetlaczu.
3. Nacisnąć przycisk „START/STOP”, aby rozpocząć odtwarzanie wybranego rytmu. W celu zatrzymania odtwarzania nacisnąć ponownie przycisk „START/STOP”.

Wybór utworu demonstracyjnego

1. Nacisnąć przycisk „DEMO”, aby wejść w tryb wyboru utworu demonstracyjnego.
2. Wybrać utwór demonstracyjny za pomocą obracania potencjometru „NUMERICAL SEL” - kod i nazwa utworu demonstracyjnego pojawią się na wyświetlaczu.

Podwójny ton (sposób 1)

1. Wejść w tryb wyboru tonu i wybrać ton główny.
2. Nacisnąć przycisk „DOUBLE VOICE”, aby wejść w tryb wyboru podwójnego tonu.
3. Wybrać drugi ton za pomocą obracania potencjometru „NUMERICAL SEL” - kod i nazwa tonu pojawią się na wyświetlaczu.

Dynamika klawiatury

Użyć przycisku „TOUCH”, aby włączyć lub wyłączyć dynamikę klawiatury.

Podział klawiatury

1. Wejść w tryb wyboru tonu i wybrać ton główny.
2. Nacisnąć przycisk „SPLIT”, aby wejść w tryb podziału klawiatury.
3. Wybrać ton za pomocą obracania potencjometru „NUMERICAL SEL” - kod i nazwa tonu pojawią się na wyświetlaczu.
4. Nacisnąć ponownie przycisk „SPLIT”, aby wyłączyć podział klawiatury.

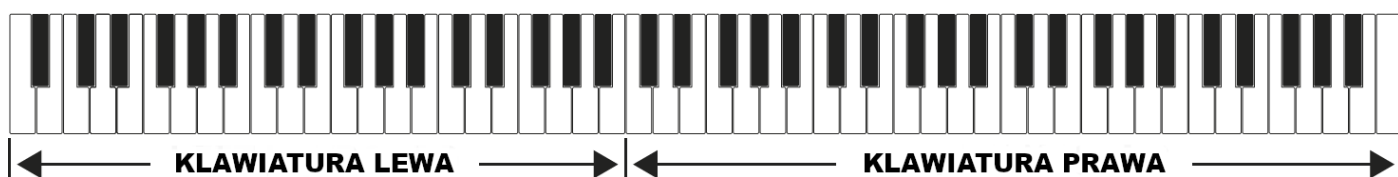

Transpozycja

1. Nacisnąć przycisk „TRANSPOSE”, aby wejść w tryb transpozycji.
2. Ustawić tonację za pomocą obracania potencjometru „NUMERICAL SEL” - obrót w lewo obniża ją, a obrót w prawo - podnosi ją.
3. Zakres ustawienia tonacji: 12 półtonów.

Odtwarzanie plików MP3

1. Włożyć pamięć przenośną USB z plikami MP3 do gniazda USB-A - odtwarzanie rozpocznie się automatycznie po 3 sekundach.
2. Nacisnąć przycisk „PLAY”, aby rozpocząć odtwarzanie / zatrzymać odtwarzany plik MP3.
3. Krótko nacisnąć przycisk „MP3 VOL-” lub „MP3 VOL+”, aby przejść do poprzedniego lub następnego pliku MP3.
4. Nacisnąć i przytrzymać przycisk „MP3 VOL-” lub „MP3 VOL+”, aby zmniejszyć lub zwiększyć głośność odtwarzania pliku MP3.

Nagrywanie

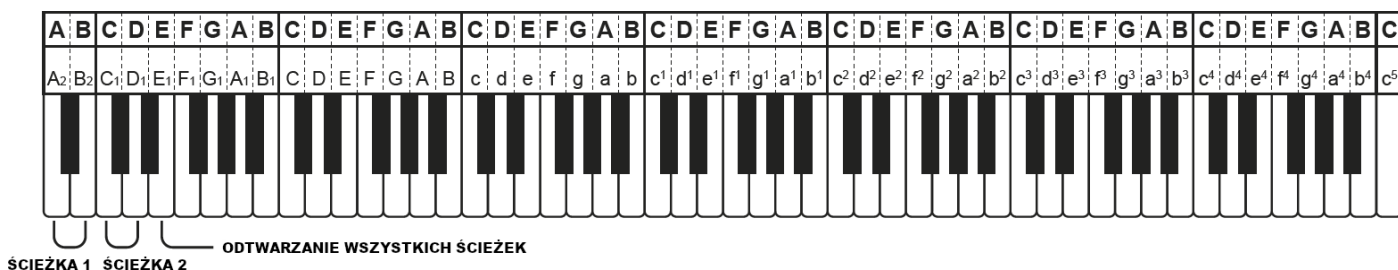

Ścieżka 1 - nagrywanie i odtwarzanie

1. Przytrzymać przycisk „EFFECT” i nacisnąć biały klawisz A₂ w strefie ścieżki 1, aby rozpocząć nagrywanie ścieżki 1.
2. Moment początku nagrania wyznacza naciśnięcie białego klawisza lub pedału.
3. Przytrzymać przycisk „EFFECT” i nacisnąć biały klawisz A₂ w strefie ścieżki 1, aby zatrzymać nagrywanie ścieżki 1.
4. Przytrzymać przycisk „EFFECT” i nacisnąć biały klawisz B₂ w strefie ścieżki 1, aby odtworzyć nagranie ścieżki 1.

Ścieżka 2 - nagrywanie i odtwarzanie

1. Przytrzymać przycisk „EFFECT” i nacisnąć biały klawisz C₁ w strefie ścieżki 2, aby rozpocząć nagrywanie ścieżki 2.
2. Moment początku nagrania wyznacza naciśnięcie białego klawisza lub pedału.
3. Przytrzymać przycisk „EFFECT” i nacisnąć biały klawisz C₁ w strefie ścieżki 2, aby zatrzymać nagrywanie ścieżki 2.

4. Przytrzymać przycisk „EFFECT” i nacisnąć biały klawisz D₁ w strefie ścieżki 2, aby odtworzyć nagranie ścieżki 2.

Odtwarzanie ścieżki 1 i ścieżki 2

Przytrzymać przycisk „EFFECT” i nacisnąć biały klawisz E₁, aby rozpocząć odtwarzanie ścieżki 1 oraz ścieżki 2.

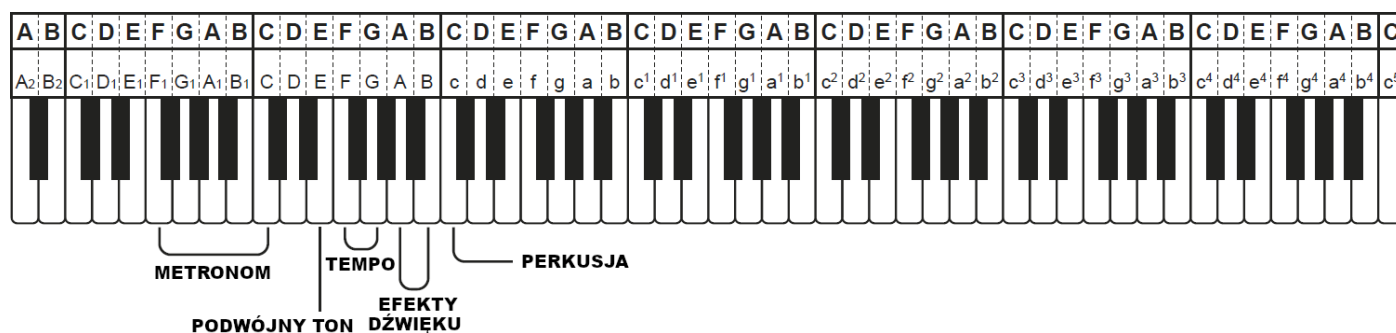

Metronom

1. Przytrzymać przycisk „EFFECT” i nacisnąć biały klawisz F₁, aby włączyć / wyłączyć metronom.
2. Przytrzymać przycisk „EFFECT” i nacisnąć jeden z białych klawiszy G₁-C, aby wybrać jedno z czterech metrum metronomu.
3. Przytrzymać przycisk „EFFECT” i nacisnąć jeden z białych klawiszy F-G, aby wybrać tempo metronomu.

Podwójny ton (sposób 2)

1. Wejść w tryb wyboru tonu i wybrać ton główny.
2. Przytrzymać przycisk „EFFECT” i nacisnąć biały klawisz E, aby wejść w tryb wyboru podwójnego tonu.
3. Wybrać drugi ton za pomocą obracania potencjometru „NUMERICAL SEL” - kod i nazwa tonu pojawiają się na wyświetlaczu.
4. Przytrzymać przycisk „EFFECT” i nacisnąć biały klawisz E, aby wyłączyć podwójny ton.

Efekty dźwięku

1. Nacisnąć i przytrzymać przycisk „EFFECT”, a następnie nacisnąć biały klawisz A, aby włączyć lub wyłączyć efekt vibrato.
2. Nacisnąć i przytrzymać przycisk „EFFECT”, a następnie nacisnąć biały klawisz B, aby włączyć lub wyłączyć efekt sustain.

Perkusja

Przytrzymać przycisk „EFFECT” i nacisnąć biały klawisz c, aby włączyć lub wyłączyć perkusję klawiatury.

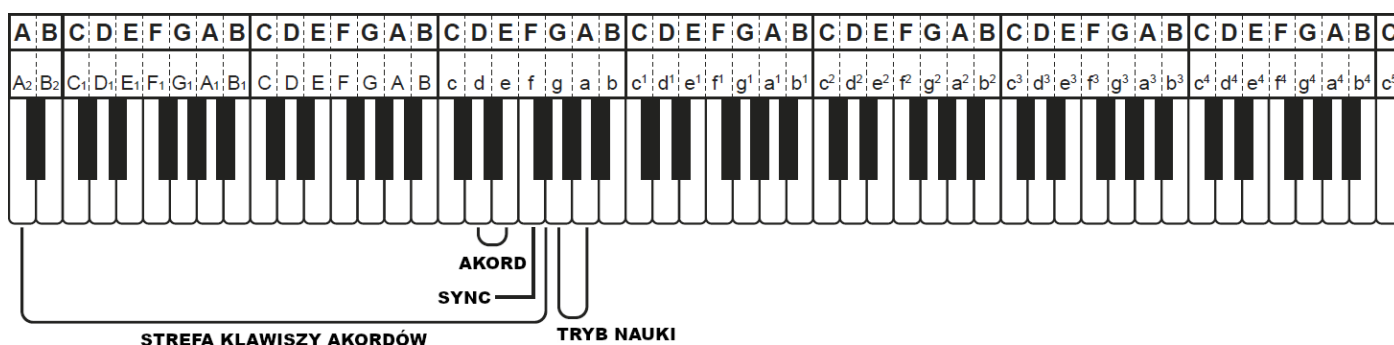

Akord jedнопalcowy

1. W trakcie odtwarzania rytmu przytrzymać przycisk „EFFECT” i nacisnąć biały klawisz d, aby wejść w tryb akordu jedнопalcowego. Rozpocząć grę za pomocą klawiszy ze strefy klawiszy akordów.
2. Nacisnąć przycisk „START/STOP”, aby zatrzymać odtwarzanie rytmu. Przytrzymać przycisk „EFFECT” i nacisnąć biały klawisz d, aby wyjść z trybu akordu jedнопalcowego.

Akord wielopalcowy

1. W trakcie odtwarzania rytmu przytrzymać przycisk „EFFECT” i nacisnąć biały klawisz e, aby wejść w tryb akordu wielopalcowego. Rozpocząć grę za pomocą klawiszy ze strefy klawiszy akordów.
2. Nacisnąć przycisk „START/STOP”, aby zatrzymać odtwarzanie rytmu. Przytrzymać przycisk „EFFECT” i nacisnąć biały klawisz e, aby wyjść z trybu akordu wielopalcowego.

Synchronizacja akordu akompaniującego z rytmem

1. W trybie akordu przytrzymać przycisk „EFFECT” i nacisnąć biały klawisz f, aby wejść w tryb synchronizacji akordu akompaniującego z rytmem.
2. Wybrać akord za pomocą klawiszy ze strefy klawiszy akordów.
3. Nacisnąć przycisk „START/STOP”, aby wyłączyć i grać z akompaniamentem.

Tryb nauki

Tryb „SINGLE-KEY”

1. Przytrzymać przycisk „EFFECT” i nacisnąć biały klawisz g, aby wejść w tryb nauki „SINGLE-KEY”.
2. Po rozpoczęciu odtwarzania utworu użytkownik musi zagrać na klawiszach odpowiadających głównej melodii. Jeżeli nie zagra ich prawidłowo, urządzenie powtórzy sekcję, a jeżeli zagra prawidłowo - urządzenie przejdzie do kolejnej sekcji aż do końca utworu.
3. Przytrzymać przycisk „EFFECT” i nacisnąć biały klawisz g, aby wyjść z trybu nauki „SINGLE-KEY”.

Tryb „ENSEMBLE”

1. Przytrzymać przycisk „EFFECT” i nacisnąć biały klawisz a, aby wejść w tryb nauki „ENSEMBLE”.
2. Po rozpoczęciu odtwarzania utworu użytkownik musi zagrać na klawiszach odpowiadających głównej melodii do akompaniamentu. Jeżeli żaden klawisz nie zostanie naciśnięty przez 5 sekund, wówczas główna melodia zostanie odtworzona automatycznie.
3. Przytrzymać przycisk „EFFECT” i nacisnąć biały klawisz a, aby wyjść z trybu nauki „ENSEMBLE”.

Tabela tonów

| | | | |
|--|---|--|---|
| 000 Acoustic grand piano | 068 Oboe | 136 flute | 204 Treble Saxophone 1 |
| 001 Bright piano | 069 British tube | 137 Bang di | 205 Alto Saxophone 1 |
| 002 TVU piano | 070 Bassoon tube | 138 guzheng | 206 Alto Saxophone 1 |
| 003 Bar piano | 071 Clarinet | 139 Qudl | 207 Upper bass saxophone 1 |
| 004 Electric piano 1 | 072 Piccolo | 140 Acoustic grand piano 1 | 208 Oboe 1 |
| 005 Electric piano 2 | 073 flute | 141 Bright Piano 1 | 209 British tube 1 |
| 006 Harpsichord | 074 Wooden flute | 142 TVU Piano 1 | 210 Bassoon tube 1 |
| 007 Clavichord | 075 Panpipe | 143 Bar Piano 1 | 211 Clarinet 1 |
| 008 Pianist | 076 Bottle blowing | 144 Electric piano 1-1 | 212 Piccolo 1 |
| 009 carillon | 077 Chiba (Japanese musical instrument) | 145 Electric piano 2-1 | 213 Flute 1 |
| 010 Eight tone box | 078 whistle | 146 Harpsichord 1 | 214 Wooden flute 1 |
| 011 Vibrating Harp | 079 ocarina | 147 Clavichord 1 | 215 Peidi 1 |
| 012 Mellotron | 080 Synthetic tonic 1 (square wave) | 148 Pianist 1 | 216 Bottle blowing 1 |
| 013 Xylophone | 081 Synthetic tonic 2 (saw tooth wave) | 149 Zhong Qin 1 | 217 Chiba (Japanese musical instrument) 1 |
| 014 Guan Zhongqin | 082 Synthetic tonic 3 | 150 Music box 1 | 218 Whistle 1 |
| 015 Desi Maqin | 083 Synthetic tonic 4 | 151 Vibrating harp 1 | 219 Ocarina 1 |
| 016 Electric organ | 084 Synthetic tonic 5 | 152 Marimba 1 | 220 Synthetic tonic 1 (square wave 1) |
| 017 Percussion organ | 085 Synthetic tonic 6 (human voice) | 153 Xylophone 1 | 221 Synthetic tonic 2 (sawtooth wave 1) |
| 018 Rock organ | 086 Synthetic tonic 7 (parallel fifth) | 154 Guan Zhongqin 1 | 222 Synthetic tonic 3 (Calliope lead 1) |
| 019 Church organ | 087 Synthetic tonic 8 (bass plus tonic) | 155 Desimaqin 1 | 223 Synthetic tonic 4 (chip lead 1) |
| 020 reed organ | 088 Synthetic voice 1 (New Century) | 156 Electric organ 1 | 224 Synthetic tonic 5 (cherang 1) |
| 021 accordion | 089 Synthetic voice 2 (warm) | 157 Percussion organ 1 | 225 Synthetic tonic 6 (vocal 1) |
| 022 harmonica | 090 Synthetic voice 3 | 158 Rock organ 1 | 226 Synthetic tonic 7 (parallel fifth 1) |
| 023 Tango Accordion | 091 Synthetic voice 4 (Chorus) | 159 Church organ 1 | 227 Synthetic tonic 8 (bass plus tonic 1) |
| 024 Guitar (nylon) | 092 Synthetic voice 5 | 160 Reed organ 1 | 228 Synthetic voice 1 (new century 1) |
| 025 Guitar (steel string) | 093 Synthetic voice 6 (metallic sound) | 161 Accordion 1 | 229 Synthetic voice 2 (warm 1) |
| 026 Guitar (Jazz) | 094 Synthetic voice 7 (halo) | 162 Harmonica 1 | 230 Synthetic voice 3 (polysynth 1) |
| 027 Guitar (original) | 095 Synthetic voice 8 | 163 Tango accordion 1 | 231 Synthetic voice 4 (Chorus 1) |
| 028 Guitar (muffled) | 096 Synthetic effect 1 rain sound | 164 Guitar (nylon) 1 | 232 Synthetic voice 5 (bowed 1) |
| 029 Broken guitar | 097 Composite effect 2 track | 165 Guitar (steel string) 1 | 233 Synthetic voice 6 (metallic sound 1) |
| 030 Strong broken guitar | 098 Synthetic effect 3 crystal | 166 Guitar (Jazz) 1 | 234 Synthetic voice 7 (halo 1) |
| 031 Guitar Harmonics | 099 Synthetic effect 4 atmosphere | 167 Guitar (original) 1 | 235 Synthetic voice 8 (sweep1) |
| 032 Bass Cello (fingered) | 100 Synthetic effect 5 bright | 168 Guitar (muffled) 1 | 236 Synthetic effect 1 rain sound 1 |
| 033 Electric bass guitar (fingered) | 101 Synthetic effect 6 ghosts | 169 Broken guitar 1 | 237 Composite effect 2 track 1 |
| 034 Electric bass guitar (with paddle) | 102 Synthetic effect 7 echo | 170 Strong broken guitar 1 | 238 Synthetic effect 3 crystal 1 |
| 035 Wugebeishi | 103 Synthetic effect 8 science fiction | 171 Guitar overtone 1 | 239 Synthetic effect 4 atmosphere 1 |
| 036 Bass 1 (thumb tapping) | 104 Sita Qin | 172 Bass Cello (fingered) 1 | 240 Synthetic effect 5 bright 1 |
| 037 Bass 2 (thumb tapping) | 105 Turtledove Harp | 173 Electric bass guitar (fingered) 1 | 241 Synthetic effect 6: Ghost 1 |
| 038 Synthetic bass-1 | 106 Three stringed piano | 174 Electric bass guitar (with paddle) 1 | 242 Synthetic effect 7 echo 1 |
| 039 Synthetic bass-2 | 107 guzheng | 175 Wugebeishi 1 | 243 Synthetic effect 8 science fiction 1 |
| 040 violin | 108 Calimba | 176 Bass 3 (thumb tapping) | 244 Sitar 1 |
| 041 Viola | 109 bagpipe | 177 Bass 4 (thumb tapping) | 245 Turtledove 1 |
| 042 cello | 110 Ancient violin | 178 Synthetic bass-3 | 246 Three stringed Piano 1 |
| 043 Double bass | 111 Shanai | 179 Synthetic bass-4 | 247 Guzheng 1 |
| 044 Trill string | 112 Ringing tone | 180 Violin 1 | 248 Calimba 1 |
| 045 Pizzicato Strings | 113 Elder brother | 181 Viola 1 | 249 Bagpipes 1 |
| 046 Orchestral Harp | 114 Steel drum | 182 Cello 1 | 250 Viola 1 |
| 047 timpani | 115 Wooden fish | 183 Double bass 1 | 251 Sannaqin 1 |
| 048 String ensemble-1 | 116 osu | 184 Vibrato string 1 | 252 Ringtone 1 |
| 049 String ensemble-2 | 117 Melody Alto drum | 185 Plucked string 1 | 253 Brother 1 |
| 050 Synthetic string-1 | 118 Synthetic drum | 186 Orchestral harp 1 | 254 Steel drum 1 |
| 051 Synthetic string-2 | 119 Echo cymbal | 187 Timpani 1 | 255 Wooden fish 1 |
| 052 Church choral harmony | 120 Guitar string scraping noise | 188 String ensemble-3 | 256 Taigu 1 |
| 053 Vocal Harmony | 121 Play a breath sound | 189 String ensemble-4 | 257 Melody Alto drum 1 |
| 054 Synth Voice | 122 Wave sound | 190 Synthetic string-3 | 258 Synthetic drum 1 |
| 055 Orchestral ensemble | 123 Blindsong | 191 Synthetic string-4 | 259 Echo cymbal 1 |
| 056 trumpet | 124 Telephone ring | 192 Church choir harmony 1 | 260 Guitar string scraping noise 1 |
| 057 Trombone | 125 helicopter | 193 Vocal harmony 1 | 261 Play air tone 1 |
| 058 Tuba | 126 Applause | 194 Synthetic voice 1 | 262 Wave sound 1 |
| 059 Muffled horn | 127 shot | 195 Orchestra 1 | 263 Birdsong 1 |
| 060 French | 128 dulcimer | 196 Small 1 | 264 Telephone bell 1 |
| 061 Wind Ensemble | 129 Zheng | 197 Trombone 1 | 265 Helicopter 1 |
| 062 Synthetic wind-1 | 130 Zhongruan | 198 Bass 1 | 266 Applause 1 |
| 063 Synthetic guangle-2 | 131 Pipa | 199 Muffled horn 1 | 267 Gunshot 1 |
| 064 Treble Saxophone | 132 Big suona | 200 France 1 | 268 Dulcimer 1 |
| 065 Alto Saxophone | 133 Suona | 201 Wind Ensemble 1 | 269 Zheng 1 |
| 066 NO.2 Alto Saxophone | 134 erhu fiddle | 202 Synthetic guangle-3 | 270 Zhongruan 1 |
| 067 baritone saxophone | 135 Yuehu | 203 Synthetic guangle-4 | 271 Pipa 1 |

| | | | | | | | |
|-----|---------------------------------------|-----|---|-----|--------------------------------------|-----|---------------------------------------|
| 272 | Blg suona 1 | 340 | France 2 | 408 | Dulcimer 2 | 476 | Small 3 |
| 273 | Suona 1 | 341 | Wind Ensemble 2 | 409 | Zheng 2 | 477 | Trombone 3 |
| 274 | Erhu 1 | 342 | Synthetic guangle-5 | 410 | Zhongruan 2 | 478 | Bass 3 |
| 275 | Yuehu 1 | 343 | Synthetic guangle-6 | 411 | Pipa 2 | 479 | Muffled horn 3 |
| 276 | Flute 1 | 344 | Treble Saxophone 2 | 412 | Blg suona 2 | 480 | France 3 |
| 277 | Bang di 1 | 345 | Alto Saxophone 2 | 413 | Suona 2 | 481 | Wind Ensemble 3 |
| 278 | Guzheng 1 | 346 | NO.2 Alto Saxophone 2 | 414 | Erhu 2 | 482 | Synthetic wind-7 |
| 279 | Qudi 1 | 347 | Upper bass saxophone 2 | 415 | Yuehu 2 | 483 | Synthetic wind-8 |
| 280 | Acoustic grand piano 2 | 348 | Oboe 2 | 416 | Flute 2 | 484 | Treble Saxophone 3 |
| 281 | Bright piano 2 | 349 | British tube 2 | 417 | Bang di 2 | 485 | Alto Saxophone 3 |
| 282 | TVU piano 2 | 350 | Bassoon tube 2 | 418 | Guzheng 2 | 486 | Saxophone 3 Alto |
| 283 | Bar piano 2 | 351 | Clarinet 2 | 419 | Qudi 2 | 487 | Upper bass saxophone 3 |
| 284 | Electric piano 1-2 | 352 | Piccolo 2 | 420 | Acoustic grand piano 3 | 488 | Oboe 3 |
| 285 | Electric piano 2-2 | 353 | Flute 2 | 421 | Bright piano 3 | 489 | British tube 3 |
| 286 | Harpichord 2 | 354 | Wooden flute 2 | 422 | TVU piano 3 | 490 | Bassoon tube 3 |
| 287 | Clavichord 2 | 355 | Paidi 2 | 423 | Bar piano 3 | 491 | Clarinet 3 |
| 288 | Pianist 2 | 356 | Bottle blowing sound 2 | 424 | Electric piano 1-3 | 492 | Piccolo 3 |
| 289 | Zhong Qin 2 | 357 | Chiba (Japanese musical instrument 2) | 425 | Electric piano 2-3 | 493 | Flute 3 |
| 290 | Music box 2 | 358 | Whistle 2 | 426 | Harpichord 3 | 494 | Wooden flute 3 |
| 291 | Vibrating harp 2 | 359 | Ocarina 2 | 427 | Clavichord 3 | 495 | Paidi 3 |
| 292 | Marimba 2 | 360 | Synthetic tonic 1 (square wave 2) | 428 | Steel piano 3 | 496 | Bottle blowing sound 3 |
| 293 | Xylophone 2 | 361 | Synthetic tonic 2 (sawtooth wave 2) | 429 | Zhong Qin 3 | 497 | Chiba (Japanese musical instrument 3) |
| 294 | Guan Zhongdin 2 | 362 | Composite lead 3 | 430 | Music box 3 | 498 | Whistle 3 |
| 295 | Desima Qin 2 | 363 | Synthetic tonic 4 (chip lead 2) | 431 | Vibrating harp 3 | 499 | Ocarina 3 |
| 296 | Electric organ 2 | 364 | Synthetic tonic 5 (charang 2) | 432 | Marimba 3 | 500 | Synthetic tonic 1 (square wave 3) |
| 297 | Percussion organ 2 | 365 | Synthetic tonic 6 (vocal 2) | 433 | Xylophone 3 | 501 | Synthetic tonic 2 (sawtooth wave 3) |
| 298 | Rock organ 2 | 366 | Synthetic tonic 7 (parallel pentameter 2) | 434 | Guan Zhongdin 3 | 502 | Call lead 3 |
| 299 | Church organ 2 | 367 | Synthetic tonic 8 (bass plus tonic 2) | 435 | Desimaqin 3 | 503 | Synthetic tonic 4 (chip lead 3) |
| 300 | Reed organ 2 | 368 | Synthetic voice 1 (New Century 2) | 436 | Electric organ 3 | 504 | Synthetic tonic 5 (charang 3) |
| 301 | Accordion 2 | 369 | Synthetic voice 2 (warm 2) | 437 | Percussion organ 3 | 505 | Synthetic tonic 6 (vocal 3) |
| 302 | Harmonica 2 | 370 | Synthetic voice 3 (polysynth 2) | 438 | Rock organ 3 | 506 | Synthetic tonic 7 (parallel pentad 3) |
| 303 | Tango accordion 2 | 371 | Synthetic voice 4 (Chorus 2) | 439 | Church organ 3 | 507 | Synthetic tonic 8 (bass plus tonic 3) |
| 304 | Guitar (nylon) 2 | 372 | Synthetic voice 5 (bowed 2) | 440 | Reed organ 3 | 508 | Synthetic voice 1 (new century 3) |
| 305 | Guitar (steel string) 2 | 373 | Synthetic voice 6 (metallic sound 2) | 441 | Accordion 3 | 509 | Synthetic voice 2 (warm 3) |
| 306 | Guitar (Jazz) 2 | 374 | Synthetic voice 7 (Halo 2) | 442 | Harmonica 3 | 510 | Polyphony 3 |
| 307 | Guitar (original) 2 | 375 | Synthetic voice 8 (sweep2) | 443 | Tango accordion 3 | 511 | Synthetic voice 4 (Chorus 3) |
| 308 | Guitar (muffled) 2 | 376 | Synthetic effect 1 rain sound 2 | 444 | Guitar (nylon) 3 | 512 | Synthetic voice 5 (bowed 3) |
| 309 | Broken guitar 2 | 377 | Composite effect 2 track 2 | 445 | Guitar (steel string) 3 | 513 | Synthetic voice 6 (metallic sound 3) |
| 310 | Strong broken guitar 2 | 378 | Synthetic effect 3 crystal 2 | 446 | Guitar (Jazz) 3 | 514 | Synthetic voice 7 (Halo 3) |
| 311 | Guitar overtone 2 | 379 | Synthetic effect 4 atmosphere 2 | 447 | Guitar (original) 3 | 515 | Synthetic voice 8 (sweep3) |
| 312 | Bass Cello (fingered) 2 | 380 | Synthetic effect 5 bright 2 | 448 | Guitar (muffled) 3 | 516 | Synthetic effect 1 rain sound 3 |
| 313 | Electric bass guitar (fingering) 2 | 381 | Synthetic effect 6 ghost 2 | 449 | Broken guitar 3 | 517 | Composite effect 2 track 3 |
| 314 | Electric bass guitar (using paddle) 2 | 382 | Synthetic effect 7 echo 2 | 450 | Strong broken guitar 3 | 518 | Synthetic effect 3 crystal 3 |
| 315 | Wugebelshi 2 | 383 | Synthetic effect 8 science fiction 2 | 451 | Guitar overtone 3 | 519 | Synthetic effect 4 atmosphere 3 |
| 316 | Bass 5 (thumb tapping) | 384 | Sitar 2 | 452 | Bass Cello (fingered) 3 | 520 | Synthetic effect 5 bright 3 |
| 317 | Bass 6 (thumb tapping) | 385 | Turtledove 2 | 453 | Electric bass guitar (fingering) 3 | 521 | Synthetic effect 6 ghost 3 |
| 318 | Synthetic bass-5 | 386 | Three stringed piano 2 | 454 | Electric bass guitar (with paddle) 3 | 522 | Synthetic effect 7 echo 3 |
| 319 | Synthetic bass-6 | 387 | Guzheng 2 | 455 | Wugebelshi 3 | 523 | Synthetic effect 8.3 |
| 320 | Violin 2 | 388 | Calimba 2 | 456 | Bass 7 (thumb tapping) | 524 | Sitar 3 |
| 321 | Viola 2 | 389 | Bagpipes 2 | 457 | Bass 8 (thumb tapping) | 525 | Turtledove harp 3 |
| 322 | Cello 2 | 390 | Viola 2 | 458 | Synthetic bass-7 | 526 | Three stringed piano 3 |
| 323 | Double Bass 2 | 391 | Sannaoin 2 | 459 | Synthetic bass-8 | 527 | Guzheng 3 |
| 324 | Vibrato string 2 | 392 | Ringtone 2 | 460 | Violin 3 | 528 | Calimba 3 |
| 325 | Plucked string 2 | 393 | Brother 2 | 461 | Viola 3 | 529 | Bagpipes 3 |
| 326 | Orchestral harp 2 | 394 | Steel drum 2 | 462 | Cello 3 | 530 | Viola 3 |
| 327 | Timpani 2 | 395 | Wooden fish 2 | 463 | Double bass 3 | 531 | Sannaoin 3 |
| 328 | String ensemble-5 | 396 | Taigu 2 | 464 | Trill string 3 | 532 | Ringtone 3 |
| 329 | String ensemble-6 | 397 | Melody Alto drum 2 | 465 | Plucked string 3 | 533 | Brother 3 |
| 330 | Synthetic string-5 | 398 | Synthetic drum 2 | 466 | Orchestral harp 3 | 534 | Steel drum 3 |
| 331 | Synthetic string-6 | 399 | Echo cymbal 2 | 467 | Timpani 3 | 535 | Wooden fish 3 |
| 332 | Church choir harmony 2 | 400 | Guitar string scraping noise 2 | 468 | String ensemble-7 | 536 | Taigu 3 |
| 333 | Vocal harmony 2 | 401 | Play air tone 2 | 469 | String ensemble-8 | 537 | Melody Alto drum 3 |
| 334 | Synthetic voice 2 | 402 | Wave sound 2 | 470 | Synthetic string-7 | 538 | Synthetic drum 3 |
| 335 | Orchestra 2 | 403 | Birdsong 2 | 471 | Synthetic string-8 | 539 | Echo cymbal 3 |
| 336 | Small 2 | 404 | Telephone bell 2 | 472 | Church choir harmony 3 | 540 | Guitar string scraping noise 3 |
| 337 | Trombone 2 | 405 | Helicopter 2 | 473 | Vocal harmony 3 | 541 | Play air 3 |
| 338 | Bass 2 | 406 | Applause 2 | 474 | Synthetic voice 3 | 542 | Wave sound 3 |
| 339 | Muffled horn 2 | 407 | Gunshot 2 | 475 | Orchestra 3 | 543 | Birdsong 3 |

| | |
|--|---|
| 544 Telephone ring 3 | 612 Church choir Harmony 4 |
| 545 Helicopter 3 | 613 Vocal Harmony 4 |
| 546 Applause 3 | 614 Synthetic voice 4 |
| 547 Gunshot 3 | 615 Orchestra 4 |
| 548 Dulcimer 3 | 616 Small 4 |
| 549 Zheng 3 | 617 Trombone 4 |
| 550 Zhongruan 3 | 618 Bass 4 |
| 551 Pipa 3 | 619 Muffled horn 4 |
| 552 Suona 3 | 620 France 4 |
| 553 Suona 3 | 621 Wind Ensemble 4 |
| 554 Erhu 3 | 622 Synthetic wind-9 |
| 555 Yuehu 3 | 623 Synthetic wind-10 |
| 556 Flute 3 | 624 Treble Saxophone 4 |
| 557 Bang Di 3 | 625 NO.2 Alto Saxophone 4 |
| 558 Guzheng 3 | 626 Alto Saxophone 4 |
| 559 Qudi 3 | 627 Upper bass saxophone 4 |
| 560 Acoustic grand piano 4 | 628 Oboe 4 |
| 561 Bright piano 4 | 629 British tube 4 |
| 562 TVU piano 4 | 630 Bassoon tube 4 |
| 563 Bar piano 4 | 631 Clarinet 4 |
| 564 Electric piano 1-4 | 632 Piccolo 4 |
| 565 Electric piano 2-4 | 633 Flute 4 |
| 566 Harpsichord 4 | 634 Wooden flute 4 |
| 567 Clavichord 4 | 635 Pald 4 |
| 568 Pianist 4 | 636 Bottle blowing 4 |
| 569 Zhong Qin 4 | 637 Chiba (Japanese musical instrument 4) |
| 570 Music box 4 | 638 Whistle 4 |
| 571 Vibrating harp 4 | 639 Ocarina 4 |
| 572 Marimba 4 | 640 Synthetic tonic 1 (square wave 4) |
| 573 Xylophone 4 | 641 Synthetic tonic 2 (sawtooth wave 4) |
| 574 Guan Zhongqin 4 | 642 Call lead 4 |
| 575 Desima Qin 4 | 643 Chime lead 4 |
| 576 Electric organ 4 | 644 Synthetic tonic 5 (charang 4) |
| 577 Percussion organ 4 | 645 Synthetic tonic 6 (vocal 4) |
| 578 Rock organ 4 | 646 Synthetic tonic 7 (parallel pentad 4) |
| 579 Church organ 4 | 647 Synthetic tonic 8 (bass plus tonic 4) |
| 580 Reed organ 4 | 648 Synthetic voice 1 (new century 4) |
| 581 Accordion 4 | 649 Synthetic voice 2 (warm 4) |
| 582 Harmonica 4 | 650 Polyphony 4 |
| 583 Tango accordion 4 | 651 Synthetic voice 4 (Chorus 4) |
| 584 Guitar (nylon) 4 | 652 Synthetic voice 5 (bowed 4) |
| 585 Guitar (steel string) 4 | 653 Synthetic voice 6 (metallic sound 4) |
| 586 Guitar (Jazz) 4 | 654 Synthetic voice 7 (halo 4) |
| 587 Guitar (original) 4 | 655 Synthetic voice 8 (sweep4) |
| 588 Guitar (muffled) 4 | 656 Synthetic effect 1 rain sound 4 |
| 589 Broken guitar 4 | 657 Composite effect 2 track 4 |
| 590 Strong broken guitar 4 | 658 Synthetic effect 4 crystal 4 |
| 591 Guitar overtone 4 | 659 Synthetic effect 4 atmosphere 4 |
| 592 Bass Cello (fingered) 4 | 660 Synthetic effect 5 bright 4 |
| 593 Electric bass guitar (fingering) 4 | 661 Synthetic effect 6 ghosts 4 |
| 594 Electric bass guitar (with paddle) 4 | 662 Synthetic effect 7 echo 4 |
| 595 No Bess 4 | 663 Synthetic effect 8-4 |
| 596 Bass 9 (thumb tapping) | 664 Sitar 4 |
| 597 Bass 10 (thumb tapping) | 665 Turtledove 4 |
| 598 Synthetic bass-9 | 666 Sanxian 4 |
| 599 Synthetic bass-10 | 667 Guzheng 4 |
| 600 Violin 4 | 668 Calimba 4 |
| 601 Viola 4 | 669 Bagpipes 4 |
| 602 Cello 4 | 670 Viola 4 |
| 603 Double bass 4 | 671 Sannalqin 4 |
| 604 Vibrato string 4 | 672 Ringtone 4 |
| 605 Plucked string 4 | 673 A brother 4 |
| 606 Orchestral harp 4 | 674 Steel drum 4 |
| 607 Timpan4 | 675 Wooden fish 4 |
| 608 String ensemble-9 | 676 Talgu 4 |
| 609 String ensemble-10 | 677 Melody Alto drum 4 |
| 610 Synthetic string-9 | 678 Synthetic drum 4 |
| 611 Synthetic string-10 | 679 Echo cymbal 4 |

Tabela rytmów

| | | | | | | | |
|----|---------------------------|-----|--------------------|-----|----------------------------|-----|-------------------------|
| 0 | 16 shot Aros 1 | 86 | March 2 | 132 | 16 beat 1 | 198 | Middle East music 2 |
| 1 | 16 shot Aros 2 | 67 | March 3 | 133 | 16 beat 2 | 199 | New soul 2 |
| 2 | 16 beat ballads 1 | 68 | Merengue 1 | 134 | 16 beat 3 | 200 | Plana 2 |
| 3 | 16 beat ballads 2 | 69 | Merengue 2 | 135 | Rock music in the 1990s | 201 | Polka 4 |
| 4 | 16 beats 1 | 70 | Middle East music | 136 | Modern pop music | 202 | Polka 5 |
| 5 | 16 beats 2 | 71 | New soul music | 137 | 8-beat ballad 2 | 203 | Polka 6 |
| 6 | 16 beats 3 | 72 | Plana | 138 | 8 beat slide Dance 2 | 204 | Classic pop 2 |
| 7 | Rock 'n' roll | 73 | Polka 1 | 139 | Acid rock 2 | 205 | Pop Dance 4 |
| 8 | 1980s pop music | 74 | Polka 2 | 140 | African music 2 | 206 | Pop dance music 5 |
| 9 | 8-beat ballad | 75 | Polka 3 | 141 | African pop 2 | 207 | Pop dance music 6 |
| 10 | 8-beat slide dance | 76 | Classic pop music | 142 | Bakata 4 | 208 | Popular Samba 4 |
| 11 | Acid rock | 77 | Pop dance music 1 | 143 | Bakata 5 | 209 | Popular Samba 5 |
| 12 | African music | 78 | Pop dance music 2 | 144 | Bakata 6 | 210 | Popular Samba 6 |
| 13 | African pop | 79 | Pop dance music 3 | 145 | Bao 2, Brazil | 211 | Reggae music 3 |
| 14 | Bakata 1 | 80 | Popular Samba 1 | 146 | Bijin Dance 2 | 212 | Reggae music 4 |
| 15 | Bakata 2 | 81 | Popular Samba 2 | 147 | Big band 3 | 213 | Cuban rhythm 6 |
| 16 | Bakata 3 | 82 | Popular Samba 3 | 148 | Big band 4 | 214 | Cuban rhythm 7 |
| 17 | Bao, Brazil | 83 | Reggae Music 1 | 149 | Bruce 2 | 215 | Cuban rhythm 8 |
| 18 | Beguine | 84 | Reggae Music 2 | 150 | Orchid music 2 | 216 | Cuban rhythm 9 |
| 19 | Big band 1 | 85 | Cuban rhythm 1 | 151 | Bolero 2 | 217 | Cuban rhythm 10 |
| 20 | Big band 2 | 86 | Cuban Rhythm 2 | 152 | Posanova 6 | 218 | Salsa 2 |
| 21 | Bruce | 87 | Cuban rhythm 3 | 153 | Posanova 7 | 219 | Samba dance 3 |
| 22 | Orchid music | 88 | Cuban rhythm 4 | 154 | Posanova 8 | 220 | Samba dance 4 |
| 23 | Bolero | 89 | Cuban rhythm 5 | 155 | Posanova 9 | 221 | Slide Rock Dance 3 |
| 24 | Posanova 1 | 90 | Salsa Dance | 156 | Posanova 10 | 222 | Slide Rock Dance 4 |
| 25 | Posanova 2 | 91 | Samba dance 1 | 157 | Country dance 3 | 223 | Slow rock 3 |
| 26 | Posanova 3 | 92 | Samba dance 2 | 158 | Country dance 4 | 224 | Slow rock 4 |
| 27 | Posanova 4 | 93 | Slide Rock Dance 1 | 159 | CALIPSO 2 | 225 | Slow soul music 6 |
| 28 | Posanova 5 | 94 | Slide Rock Dance 2 | 160 | Chinese national music 4 | 226 | Slow soul music 7 |
| 29 | Country dance 1 | 95 | Slow rock 1 | 161 | Chinese national music 5 | 227 | Slow soul music 8 |
| 30 | Country dance 2 | 96 | Slow rock 2 | 162 | Chinese national music 6 | 228 | Slow soul music 9 |
| 31 | CALIPSO | 97 | Slow soul music 1 | 163 | Mini Jazz 3 | 229 | Slow soul music 10 |
| 32 | Chinese national music 1 | 98 | Slow soul music 2 | 164 | Mini Jazz 4 | 230 | Soul music 9 |
| 33 | Chinese national music 2 | 99 | Slow soul music 3 | 165 | European beat 2 | 231 | Soul music 10 |
| 34 | Chinese national music 3 | 100 | Slow soul music 4 | 166 | European Soul 2 | 232 | Soul music 11 |
| 35 | Mini Jazz 1 | 101 | Slow soul music 5 | 167 | Funk soul music 9 | 233 | Soul music 12 |
| 36 | Mini Jazz 2 | 102 | Soul music 1 | 168 | Funk soul music 10 | 234 | Soul music 13 |
| 37 | European beat | 103 | Soul music 2 | 169 | Funk soul music 11 | 235 | Happy soul 14 |
| 38 | European soul music | 104 | Soul music 3 | 170 | Funk soul 12 | 236 | Soul music 15 |
| 39 | Funk soul 1 | 105 | Soul music 4 | 171 | Funk soul music 13 | 237 | Soul music 16 |
| 40 | Funk Soul 2 | 106 | Soul music 5 | 172 | Funk soul 14 | 238 | Ghost step 2 |
| 41 | Funk soul music 3 | 107 | Soul music 6 | 173 | Funk soul 15 | 239 | Swing 7 |
| 42 | Funk soul 4 | 108 | Soul music 7 | 174 | Funk soul music 16 | 240 | Swing 8 |
| 43 | Funk soul 5 | 109 | Soul music 8 | 175 | Habanera 2 | 241 | Swing 9 |
| 44 | Funk soul music 6 | 110 | Ghost step | 176 | Multi element Rhythm 2 | 242 | Swing music 10 |
| 45 | Funk soul 7 | 111 | Swing 1 | 177 | Multi element rock music 2 | 243 | Swing 11 |
| 46 | Funk soul music 8 | 112 | Swing 2 | 178 | Haoshi electronic music 3 | 244 | Swing music 12 |
| 47 | Habanera | 113 | Swing 3 | 179 | Haoshi electronic music 4 | 245 | Swing Rhythm 2 |
| 48 | Multi element rhythm | 114 | Swing 4 | 180 | Jazz sambal | 246 | Tango 4 |
| 49 | Multi element rock music | 115 | Swing 5 | 181 | Jazz Waltz 4 | 247 | Tango 5 |
| 50 | Haoshi electronic music 1 | 116 | Swing 6 | 182 | Jazz Waltz 5 | 248 | Tango 6 |
| 51 | Haoshi electronic music 2 | 117 | Swing Rhythm | 183 | Jazz Waltz 6 | 249 | Thai Music 2 |
| 52 | Jazz sambal | 118 | Tango 1 | 184 | Jorbo 2 | 250 | Twisted Jazz 2 |
| 53 | Jazz Waltz 1 | 119 | Tango 2 | 185 | Lambada Dance 2 | 251 | Waganado 2 |
| 54 | Jazz Waltz 2 | 120 | Tango 3 | 186 | Love song 6 | 252 | Waltz 5 |
| 55 | Jazz Waltz 3 | 121 | Thai music | 187 | Love song 7 | 253 | Waltz 6 |
| 56 | Jorbo dance | 122 | Twisted Jazz | 188 | Love song 8 | 254 | Waltz 7 |
| 57 | Lambada dance | 123 | Waganado | 189 | Love song 9 | 255 | Waltz 8 |
| 58 | Love song 1 | 124 | Waltz 1 | 190 | Love song 10 | 256 | 16 shot Yalei 5 |
| 59 | Love song 2 | 125 | Waltz 2 | 191 | Mambo 3 | 257 | 16 shot Yalei 6 |
| 60 | Love song 3 | 126 | Waltz 3 | 192 | Mambo 4 | 258 | 16 shot Yalei 7 |
| 61 | Love song 4 | 127 | Waltz 4 | 193 | March 4 | 259 | 16 shot Yalei 8 |
| 62 | Love song 5 | 128 | 16 shot Yalei 1 | 194 | March 5 | 260 | 16 beat 4 |
| 63 | Mambo 1 | 129 | 16 shot Yalei 2 | 195 | March 6 | 261 | 16 beat 5 |
| 64 | Mambo 2 | 130 | 16 shot Yalei 3 | 196 | Merengue 3 | 262 | 16 beat 6 |
| 65 | March 1 | 131 | 16 shot Yalei 4 | 197 | Merengue 4 | 263 | Rock music in the '91's |

Instrukcja obsługi / User Manual

| | | | | | | | |
|-----|----------------------------|-----|-------------------------|-----|----------------------------|-----|---------------------------|
| 264 | Modern pop music | 332 | Classic pop 3 | 410 | Posanova 18 | 478 | Slide rock dance 8 |
| 265 | 8-beat ballad 3 | 333 | Pop dance music 7 | 411 | Posanova 19 | 479 | Slow rock 7 |
| 266 | 8 beat slide Dance 3 | 334 | Pop dance music 8 | 412 | Posanova 20 | 480 | Slow rock 8 |
| 267 | Acid rock 3 | 335 | Pop dance music 9 | 413 | Country dance 7 | 481 | Slow soul music 16 |
| 268 | African music 3 | 336 | Popular Samba 7 | 414 | Country dance 8 | 482 | Slow soul music 17 |
| 269 | African pop 3 | 337 | Popular Samba 8 | 415 | CALIPSO 4 | 483 | Slow soul music 18 |
| 270 | Bakata 7 | 338 | Popular Samba 9 | 416 | Chinese national music 10 | 484 | Slow soul music 19 |
| 271 | Bakata 8 | 339 | Reggae music 5 | 417 | Chinese national music 11 | 485 | Slow soul music 20 |
| 272 | Bakata 9 | 340 | Reggae music 6 | 418 | Chinese national music 12 | 486 | Soul music 25 |
| 273 | Bao 3, Brazil | 341 | Cuban rhythm 11 | 419 | Mini Jazz 7 | 487 | Soul music 26 |
| 274 | Bijin Dance 3 | 342 | Cuban rhythm 12 | 420 | Mini Jazz 8 | 488 | Soul music 27 |
| 275 | Big band 5 | 343 | Cuban rhythm 13 | 421 | European beat 4 | 489 | Soul music 28 |
| 276 | Big band 6 | 344 | Cuban rhythm 14 | 422 | European soul 4 | 490 | Soul music 29 |
| 277 | Bruce 3 | 345 | Cuban rhythm 15 | 423 | Funk soul music 25 | 491 | Soul music 30 |
| 278 | Orchid music 3 | 346 | Salsa 3 | 424 | Funk soul music 26 | 492 | Soul music 31 |
| 279 | Bolero 3 | 347 | Samba dance 5 | 425 | Funk soul music 27 | 493 | Soul music 32 |
| 280 | Posanova 11 | 348 | Samba dance 6 | 426 | Funk soul music 28 | 494 | Ghost step 4 |
| 281 | Posanova 12 | 349 | Slide Rock Dance 5 | 427 | Funk soul music 29 | 495 | Swing 19 |
| 282 | Posanova 13 | 350 | Slide rock dance 6 | 428 | Funk soul music 30 | 496 | Swing music 20 |
| 283 | Posanova 14 | 351 | Slow rock 5 | 429 | Funk soul music 31 | 497 | Swing 21 |
| 284 | Posanova 15 | 352 | Slow rock 6 | 430 | Funk soul music 32 | 498 | Swing 22 |
| 285 | Country dance 5 | 353 | Slow soul music 11 | 431 | Habanera 4 | 499 | Swing music 23 |
| 286 | Country dance 6 | 354 | Slow soul music 12 | 432 | Multi element rhythm 4 | 500 | Swing 24 |
| 287 | CALIPSO 3 | 355 | Slow soul music 13 | 433 | Multi element rock music 4 | 501 | Swing rhythm 4 |
| 288 | Chinese national music 7 | 356 | Slow soul music 14 | 434 | Haoshi electronic music 7 | 502 | Tango 10 |
| 289 | Chinese national music 8 | 357 | Slow soul music 15 | 435 | Haoshi electronic music 8 | 503 | Tango 11 |
| 290 | Chinese national music 9 | 358 | Soul music 17 | 436 | Jazz sambal | 504 | Tango 12 |
| 291 | Mini Jazz 5 | 359 | Soul music 18 | 437 | Jazz Waltz 10 | 505 | Thai music 4 |
| 292 | Mini Jazz 6 | 360 | Soul music 19 | 438 | Jazz Waltz 11 | 506 | Twisted Jazz 4 |
| 293 | European beat 3 | 361 | Soul music 20 | 439 | Jazz Waltz 12 | 507 | Waganado 4 |
| 294 | European soul 3 | 362 | Soul music 21 | 440 | Jorbo 4 | 508 | Waltz 13 |
| 295 | Funk soul music 17 | 363 | Soul music 22 | 441 | Lambada Dance 4 | 509 | Waltz 14 |
| 296 | Funk soul 18 | 364 | Soul music 23 | 442 | Love song 16 | 510 | Waltz 15 |
| 297 | Funk soul music 19 | 365 | Soul music 24 | 443 | Love song 17 | 511 | Waltz 16 |
| 298 | Funk soul music 20 | 366 | Ghost step 3 | 444 | Love song 18 | 512 | 16 shot Yalei 9 |
| 299 | Funk soul music 21 | 367 | Swing 13 | 445 | Love song 19 | 513 | 16 shot Yalei 10 |
| 300 | Funk soul music 22 | 368 | Swing music 14 | 446 | Love song 20 | 514 | 16 shot Yalei 11 |
| 301 | Funk soul music 23 | 369 | Swing 15 | 447 | Mambo 7 | 515 | 16 shot Yalei 12 |
| 302 | Funk soul music 24 | 370 | Swing 16 | 448 | Mambo 8 | 516 | 16 beat 7 |
| 303 | Habanera 3 | 371 | Swing 17 | 449 | March 10 | 517 | 16 beat 8 |
| 304 | Multi element rhythm 3 | 372 | Swing 18 | 450 | March 11 | 518 | 16 beat 9 |
| 305 | Multi element rock music 3 | 373 | Swing rhythm 3 | 451 | March 12 | 519 | Rock music in the '92's |
| 306 | Haoshi electronic music 5 | 374 | Tango 7 | 452 | Merengue 7 | 520 | Modern pop music |
| 307 | Haoshi electronic music 6 | 375 | Tango 8 | 453 | Merengue 8 | 521 | 8-beat ballad 4 |
| 308 | Jazz sambal | 376 | Tango 9 | 454 | Middle East music 4 | 522 | 8 beat slide Dance 4 |
| 309 | Jazz Waltz 7 | 377 | Thai music 3 | 455 | New soul 4 | 523 | Acid rock 4 |
| 310 | Jazz Waltz 8 | 378 | Twisted Jazz 3 | 456 | Plana 4 | 524 | African music 4 |
| 311 | Jazz Waltz 9 | 379 | Waganado 3 | 457 | Polka 10 | 525 | African pop 4 |
| 312 | Jorbo 3 | 380 | Waltz 9 | 458 | Polka 11 | 526 | Bakata 10 |
| 313 | Lambada Dance 3 | 381 | Waltz 10 | 459 | Polka 12 | 527 | Bakata 11 |
| 314 | Love song 11 | 382 | Waltz 11 | 460 | Classic pop 4 | 528 | Bakata 12 |
| 315 | Love song 12 | 383 | Waltz 12 | 461 | Pop dance music 10 | 529 | Bao 4, Brazil |
| 316 | Love song 13 | 384 | 16 shot Yalei 9 | 462 | Pop dance music 11 | 530 | Bijin Dance 4 |
| 317 | Love song 14 | 385 | 16 shot Yalei 10 | 463 | Pop dance music 12 | 531 | Big band 7 |
| 318 | Love song 15 | 386 | 16 shot Yalei 11 | 464 | Popular Samba 10 | 532 | Big band 8 |
| 319 | Mambo 5 | 387 | 16 shot Yalei 12 | 465 | Popular Samba 11 | 533 | Bruce 4 |
| 320 | Mambo 6 | 388 | 16 beat 7 | 466 | Popular Samba 12 | 534 | Orchid music 4 |
| 321 | March 7 | 389 | 16 beat 8 | 467 | Reggae music 7 | 535 | Bolero 4 |
| 322 | March 8 | 390 | 16 beat 9 | 468 | Reggae music 8 | 536 | Posanova 16 |
| 323 | March 9 | 391 | Rock music in the '92's | 469 | Cuban rhythm 16 | 537 | Posanova 17 |
| 324 | Merengue 5 | 392 | Modern pop music | 470 | Cuban rhythm 17 | 538 | Posanova 18 |
| 325 | Merengue 6 | 393 | 8-beat ballad 4 | 471 | Cuban rhythm 18 | 539 | Posanova 19 |
| 326 | Middle East music 3 | 394 | 8 beat slide Dance 4 | 472 | Cuban rhythm 19 | 540 | Posanova 20 |
| 327 | New soul music 3 | 395 | Acid rock 4 | 473 | Cuban rhythm 20 | 541 | Country dance 7 |
| 328 | Plana 3 | 396 | African music 4 | 474 | Salsa 4 | 542 | Country dance 8 |
| 329 | Polka 7 | 397 | African pop 4 | 475 | Samba dance 7 | 543 | CALIPSO 4 |
| 330 | Polka 8 | 398 | Bakata 10 | 476 | Samba dance 8 | 544 | Chinese national music 10 |
| 331 | Polka 9 | 399 | Bakata 11 | 477 | Slide rock dance 7 | 545 | Chinese national music 11 |

| | | | | | | | |
|-----|-----------------------|-----|----------------------------|-----|---------------------|-----|--------------------|
| 546 | Chinese folk music 12 | 560 | Multi element rhythm 4 | 574 | Love song 20 | 588 | Classic pop 4 |
| 547 | Mini Jazz 7 | 561 | Multi element rock music 4 | 575 | Mambo 7 | 589 | Pop dance music 10 |
| 548 | Mini Jazz 8 | 562 | Haoshi electronic music 7 | 576 | Mambo 8 | 590 | Pop dance music 11 |
| 549 | European beat 4 | 563 | Haoshi electronic music 8 | 577 | March 10 | 591 | Pop dance music 12 |
| 550 | European soul 4 | 564 | Jazz sambal | 578 | March 11 | 592 | Popular Samba 10 |
| 551 | Funk soul music 25 | 565 | Jazz Waltz 10 | 579 | March 12 | 593 | Popular Samba 11 |
| 552 | Funk soul music 26 | 566 | Jazz Waltz 11 | 580 | Merengue 7 | 594 | Popular Samba 12 |
| 553 | Funk soul music 27 | 567 | Jazz Waltz 12 | 581 | Merengue 8 | 595 | Reggae music 7 |
| 554 | Funk soul music 28 | 568 | Jorbo 4 | 582 | Middle East music 4 | 596 | Reggae music 8 |
| 555 | Funk soul music 29 | 569 | Lambada Dance 4 | 583 | New soul 4 | 597 | Cuban rhythm 16 |
| 556 | Funk soul music 30 | 570 | Love song 16 | 584 | Plana 4 | 598 | Cuban rhythm 17 |
| 557 | Funk soul music 31 | 571 | Love song 17 | 585 | Polka 10 | 599 | Cuban rhythm 18 |
| 558 | Funk soul music 32 | 572 | Love song 18 | 586 | Polka 11 | | |
| 559 | Habanera 4 | 573 | Love song 19 | 587 | Polka 12 | | |

Tabela utworów demonstracyjnych

| | | | | | |
|-----|--|-----|----------------------------|-----|--------------------|
| 000 | horse racing | 032 | A prune of plum | 064 | Piano Sonata |
| 001 | Whip the horse and transport grain | 033 | Moon full West Building | 065 | The Blue Danube |
| 002 | Step by step | 034 | Goodbye, Dable Mountain | 066 | yearn |
| 003 | Taihu Lake Beauty | 035 | Happy Chinese year | 067 | Tea for two |
| 004 | Osmanthus blooming in August | 036 | Dreamland | 068 | Sleigh ride |
| 005 | The Moon Over a Fountain | 037 | Grandma's Penghu bend | 069 | Red Nosed Reindeer |
| 006 | Tathagata divine palm | 038 | lover | 070 | Santa goes to town |
| 007 | Dating In The Mongoloid Tent | 039 | I wish you peace | 071 | Dream |
| 008 | Yangming Chunxiao | 040 | Pacific Hotel | 072 | Clock of time |
| 009 | Jasmine Flower | 041 | The madness of 1900 | 073 | Humorous music |
| 010 | Beaming with Joy | 042 | Family Restaurant | 074 | The Happy Farmer |
| 011 | good days | 043 | Johnny surfing | 075 | Cannon |
| 012 | childhood | 044 | Sinbad hand | 076 | Waltz Waltz |
| 013 | Purple bamboo tune | 045 | New paradise | 077 | Green sleeves |
| 014 | Auspicious three treasures | 046 | Happy birthday! | 078 | Polka |
| 015 | Love And Passion | 047 | Carmen Entr'acte | 079 | ARABESK |
| 016 | In that distant place | 048 | Short song | | |
| 017 | Song of grassland | 049 | Jingle bells | | |
| 018 | Often go home and have a look | 050 | Christmas Eve | | |
| 019 | On the way to the market | 051 | oh Santa Claus | | |
| 020 | Original Extended Remix | 052 | Holy March | | |
| 021 | Qinghai Tibet Plateau | 053 | Oh! Susanna | | |
| 022 | Same song | 054 | Moon River | | |
| 023 | Eighteen bends of mountain road | 055 | ABC letter song | | |
| 024 | Send off | 056 | Merry Christmas to you | | |
| 025 | DJRainman Remix | 057 | Six ducklings | | |
| 026 | Where peach blossoms are in full bloom | 058 | Mary has a little sheep | | |
| 027 | Entering a new era | 059 | Moonlight Bay | | |
| 028 | Give me a red rose | 060 | U.S.A | | |
| 029 | Kangding Love Song | 061 | Crazy weapon | | |
| 030 | Hot Blooded | 062 | Before the next tear drops | | |
| 031 | Beijing tune | 063 | Doggie Waltz | | |







Informacja o zużytym sprzęcie elektrycznym i elektronicznym

Głównym celem regulacji europejskich oraz krajowych jest ograniczenie ilości odpadów powstałych ze zużytego sprzętu elektrycznego i elektronicznego, zapewnienie odpowiedniego poziomu jego zbierania, odzysku i recyklingu oraz zwiększenie świadomości społecznej o jego szkodliwości dla środowiska naturalnego, na każdym etapie użytkowania sprzętu elektrycznego i elektronicznego. W związku z powyższym należy wskazać, iż gospodarstwa domowe spełniają kluczową rolę w przyczynianiu się do ponownego użycia i odzysku, w tym recyklingu zużytego sprzętu. Użytkownik sprzętu przeznaczonego dla gospodarstw domowych jest zobowiązany po jego zużyciu do oddania zbierającemu zużyty sprzęt elektryczny i elektroniczny. Należy jednak pamiętać, aby produkty należące do grupy sprzętu elektrycznego lub elektronicznego utylizowane były w uprawnionych do tego punktach zbiórki.

Table of contents

| | |
|---|----|
| Safety rules..... | 16 |
| Maintenance | 16 |
| Structure | 17 |
| Operation..... | 18 |
| Tone table..... | 22 |
| Rhythm table | 25 |
| Demo track table | 27 |
| Information about used electrical and electronic equipment..... | 28 |

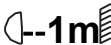
Safety rules

| | |
|---|---|
|  | Please read the user manual in detail before use. Please also keep it for future reference. The user manual contains rules for the safe use of the device. |
|  | After receiving the product, please unpack and check whether it is complete and whether there is any damage caused by transportation. If there is damage caused by transportation, please do not use this product and contact the dealer or manufacturer as soon as possible. |
|  | WARNING! THE DEVICE MUST NOT BE DISPOSED OF WITH HOUSEHOLD WASTE. This symbol indicates that this product must not be disposed of with household waste, according to the EU and your national law. In order to prevent potential damage to the environment or health, the used product must be recycled. In accordance with current legislation, unusable electrical and electronic devices must be collected separately at the designated facilities for recycling, acting on the basis of applicable environmental standards. |
|  | The product described in this manual comply with European directives and it is therefore CE marked. |
|  | Before use, make sure the housing is not damaged. |
|  | Ensure a minimum distance of 1 m between the device and flammable materials. |
|  | The device operates on the power supply marked on the housing - do not connect to power of other parameters. Disconnect the product from the power source by pulling on the power cable plug - do not directly pull the power cable! Disconnect the device from the power supply before maintenance. If you find damage to the power cable - do not use it! |
|  | The device for indoor use, do not expose to prolonged moisture. Do not expose the product to direct sunlight or other lighting devices. Do not store or use the device near a fire source! Do not install the device on a surface subjected to vibration. Do not expose the device to high temperatures! In the event of a malfunction, disconnect the device from the power supply immediately! |

Maintenance

1. The device may only be used by qualified personnel, damage caused by improper use or attempted repair is not covered by the warranty. There are no service parts inside the packaging, repairs may only be carried out by authorized service center.
2. Do not allow the device to come into contact with oil, grease or any similar liquid.
3. Regular cleaning allows of long term use and maintains proper quality of operation. Use a soft cloth to clean the device.

Structure

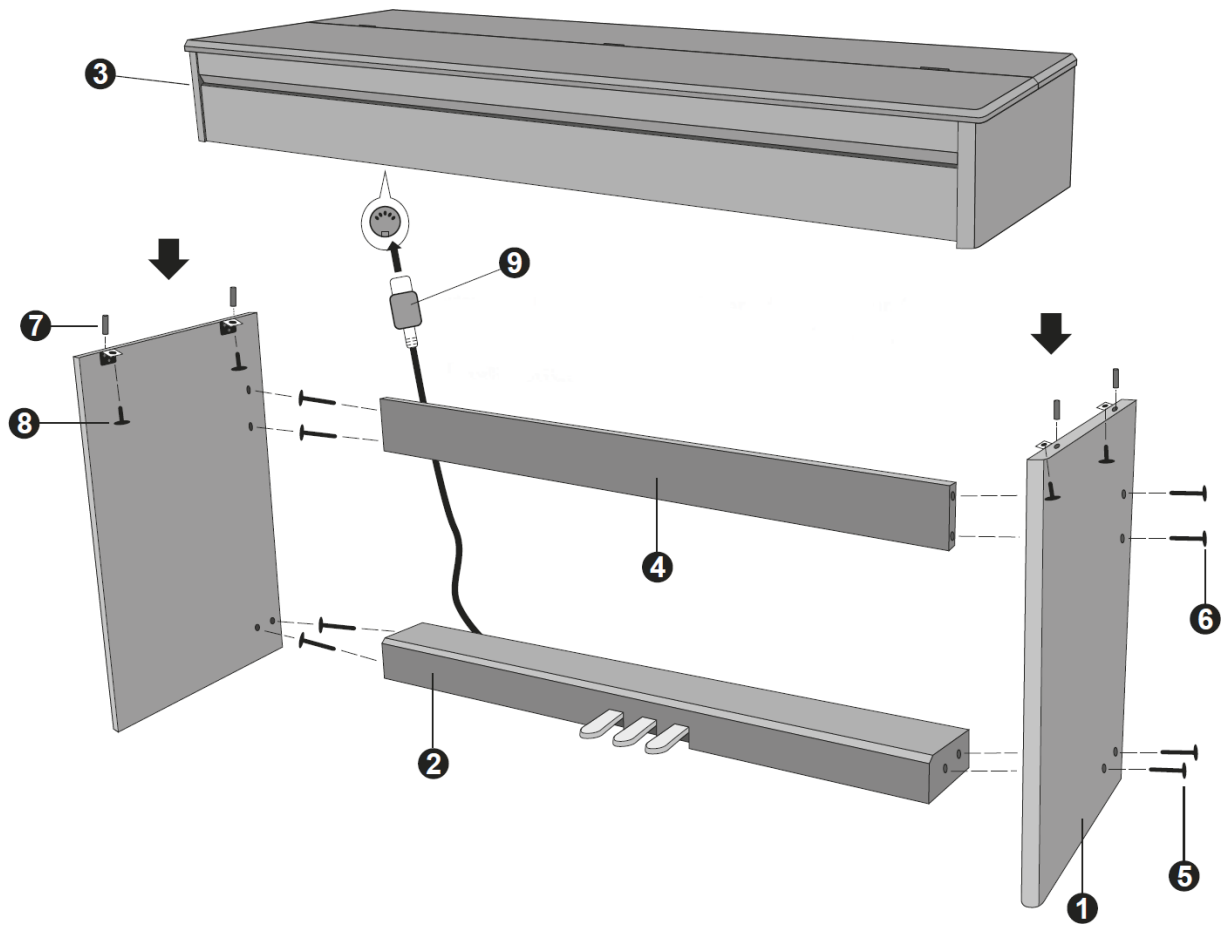

- 1. Left and right support.
- 2. Pedal cross beam.
- 3. Body.
- 4. Back plate.
- 5. Four M6x50 screws.

- 6. Four M4x50 screws.
- 7. Four 40-type bolts.
- 8. Four M6x18 screws.
- 9. Cable with pedal plug.

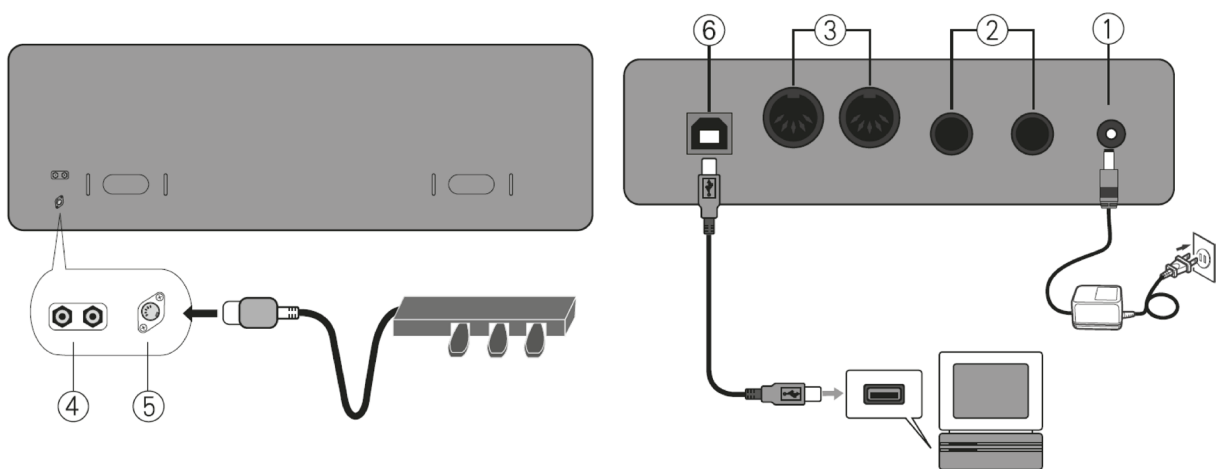

- 1. DC power input.
- 2. Audio input / output.
- 3. MIDI input / output.

- 4. Two headphone outputs.
- 5. Pedal input.
- 6. USB-B socket.

Operation

Switching on/off the device

1. Place the power cable plug in the power source, observing safety rules. Place the DC plug into the device power socket.
2. Turn the device on/off with the "POWER" button.

Volume adjustment

Use the volume control potentiometer "VOLUME" to increase or decrease the volume of the piano.

Tone selection

1. Press the "TONE" button to enter the tone selection mode.
2. Select the tone by rotating the potentiometer "NUMERICAL SEL" - the code and name of the tone will appear on the display.

Rhythm selection

1. Press the "RHYTHM" button to enter the rhythm selection mode.
2. Select the rhythm by rotating the potentiometer "NUMERICAL SEL" - the code and name of the rhythm will appear on the display.
3. Press the "START/STOP" button to start playback of the selected rhythm. Press the "START/STOP" button again to stop playback.

Demo track selection

1. Press the "DEMO" button to enter the demo track selection mode.
2. Select the demo track by rotating the "NUMERICAL SEL" potentiometer - the code and name of the demo track will appear on the display.

Dual tone (way 1)

1. Enter the tone selection mode and select the main tone.
2. Press the "DOUBLE VOICE" button to enter the dual tone selection mode.
3. Select the second tone by rotating the "NUMERICAL SEL" potentiometer - the code and name of the tone will appear on the display.

Keystroke dynamics

Use the "TOUCH" button to turn keystroke dynamics on or off.

Keyboard split

1. Enter the tone selection mode and select the main tone.
2. Press the "SPLIT" button to enter the keyboard split mode.
3. Select the tone by rotating the potentiometer "NUMERICAL SEL" - the code and name of the tone will appear on the display.
4. Press the "SPLIT" button again to turn off the keyboard split.

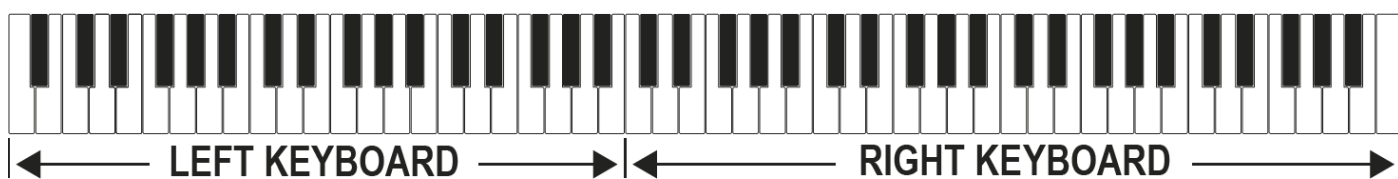

Transposition

1. Press the "TRANSCOPE" button to enter the transposition mode.
2. Set the key by rotating the "NUMERICAL SEL" potentiometer - rotating it to the left lowers it and rotating it to the right - raises it.
3. Key setting range: 12 semitones.

MP3 file playback

1. Insert a USB flash drive with MP3 files into the USB-A socket - playback will start automatically after 3 seconds.
2. Press the "PLAY" button to start playing / pause the MP3 file being played.
3. Shortly press the "MP3 VOL-" or "MP3 VOL+" button to go to the previous or next MP3 file.
4. Press and hold the "MP3 VOL-" or "MP3 VOL+" button to decrease or increase the playback volume of the MP3 file.

Recording

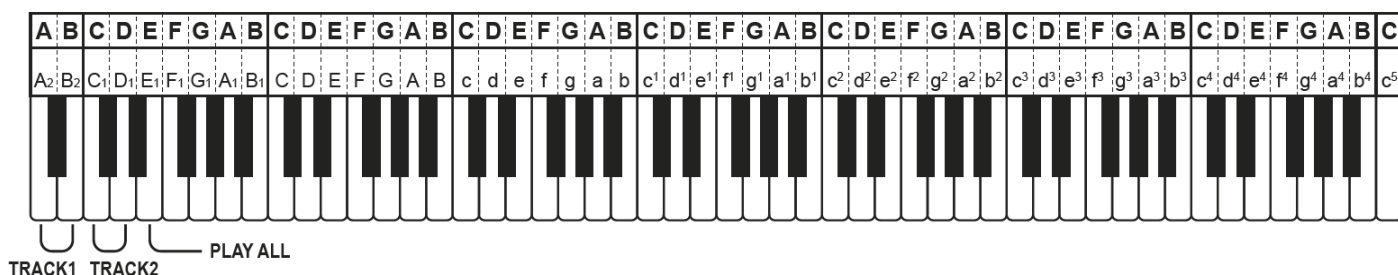

Track 1 - recording and playback

1. Hold down the "EFFECT" button and press the white A2 key in the track 1 zone to start recording track 1.
2. The moment of the beginning of the recording is determined by pressing the white key or pedal.
3. Hold down the "EFFECT" button and press the white A2 key in the track 1 zone to stop recording track 1.
4. Hold the "EFFECT" button and press the white B2 key in the track 1 zone to play the recording of track 1.

Track 2 - recording and playback

1. Hold down the "EFFECT" button and press the white C1 key in the track 2 zone to start recording track 2.
2. The moment of the beginning of the recording is determined by pressing the white key or pedal.
3. Hold down the "EFFECT" button and press the white C1 key in track 2 zone to stop recording track 2.
4. Hold down the "EFFECT" button and press the white key D1 in the track 2 zone to play the recording of track 2.

Single-finger chord

1. While playing the rhythm, hold down the "EFFECT" button and press the white d key to enter the single-finger chord mode. Start playing with the keys from the chord keys zone.
2. Press the "START/STOP" button to stop playing the rhythm. Hold down the "EFFECT" button and press the white d key to exit the single-finger chord mode.

Multi-finger chord

1. While playing the rhythm, hold down the "EFFECT" button and press the white e key to enter the multi-finger chord mode. Start playing with the keys from the chord keys zone.
2. Press the "START/STOP" button to stop playing the rhythm. Hold down the "EFFECT" button and press the white e key to exit the multi-finger chord mode.

Synchronization of the chord accompaniment with the rhythm

1. In the chord mode, hold down the "EFFECT" button and press the white f key to enter the mode of synchronization of the chord accompaniment with the rhythm.
2. Select the chord with the keys from the chord keys zone.
3. Press the "START/STOP" button to turn off and play with the accompaniment.

Learning mode

"SINGLE-KEY" mode

1. Hold down the "EFFECT" button and press the white g key to enter the "SINGLE-KEY" learning mode.
2. After the start of the song playback, the user must play the keys corresponding to the main melody. If they do not be played correctly, the device will repeat the section, and if they be played correctly - the device will move on to the next section until the end of the song.
3. Hold down the "EFFECT" button and press the white g key to exit the "SINGLE-KEY" learning mode.

"ENSEMBLE" mode

1. Hold down the "EFFECT" button and press the white key a to enter the "ENSEMBLE" learning mode.
2. After the start of playing the song, the user must play the keys corresponding to the main melody, according to the accompaniment. If no key is pressed for 5 seconds, then the main melody will be played automatically.
3. Hold down the "EFFECT" button and press the white key a to exit the "ENSEMBLE" learning mode.

Tone table

| | | | |
|--|---|--|---|
| 000 Acoustic grand piano | 068 Oboe | 136 flute | 204 Treble Saxophone 1 |
| 001 Bright piano | 069 British tube | 137 Bang di | 205 Alto Saxophone 1 |
| 002 TVU piano | 070 Bassoon tube | 138 guzheng | 206 Alto Saxophone 1 |
| 003 Bar piano | 071 Clarinet | 139 Qudl | 207 Upper bass saxophone 1 |
| 004 Electric piano 1 | 072 Piccolo | 140 Acoustic grand piano 1 | 208 Oboe 1 |
| 005 Electric piano 2 | 073 flute | 141 Bright Piano 1 | 209 British tube 1 |
| 006 Harpsichord | 074 Wooden flute | 142 TVU Piano 1 | 210 Bassoon tube 1 |
| 007 Clavichord | 075 Panpipe | 143 Bar Piano 1 | 211 Clarinet 1 |
| 008 Pianist | 076 Bottle blowing | 144 Electric piano 1-1 | 212 Piccolo 1 |
| 009 carillon | 077 Chiba (Japanese musical instrument) | 145 Electric piano 2-1 | 213 Flute 1 |
| 010 Eight tone box | 078 whistle | 146 Harpsichord 1 | 214 Wooden flute 1 |
| 011 Vibrating Harp | 079 ocarina | 147 Clavichord 1 | 215 Peidi 1 |
| 012 Mellotron | 080 Synthetic tonic 1 (square wave) | 148 Pianist 1 | 216 Bottle blowing 1 |
| 013 Xylophone | 081 Synthetic tonic 2 (saw tooth wave) | 149 Zhong Qin 1 | 217 Chiba (Japanese musical instrument) 1 |
| 014 Guan Zhongqin | 082 Synthetic tonic 3 | 150 Music box 1 | 218 Whistle 1 |
| 015 Desi Maqin | 083 Synthetic tonic 4 | 151 Vibrating harp 1 | 219 Ocarina 1 |
| 016 Electric organ | 084 Synthetic tonic 5 | 152 Marimba 1 | 220 Synthetic tonic 1 (square wave 1) |
| 017 Percussion organ | 085 Synthetic tonic 6 (human voice) | 153 Xylophone 1 | 221 Synthetic tonic 2 (sawtooth wave 1) |
| 018 Rock organ | 086 Synthetic tonic 7 (parallel fifth) | 154 Guan Zhongqin 1 | 222 Synthetic tonic 3 (Calliope lead 1) |
| 019 Church organ | 087 Synthetic tonic 8 (bass plus tonic) | 155 Desimaqin 1 | 223 Synthetic tonic 4 (chip lead 1) |
| 020 reed organ | 088 Synthetic voice 1 (New Century) | 156 Electric organ 1 | 224 Synthetic tonic 5 (cherang 1) |
| 021 accordion | 089 Synthetic voice 2 (warm) | 157 Percussion organ 1 | 225 Synthetic tonic 6 (vocal 1) |
| 022 harmonica | 090 Synthetic voice 3 | 158 Rock organ 1 | 226 Synthetic tonic 7 (parallel fifth 1) |
| 023 Tango Accordion | 091 Synthetic voice 4 (Chorus) | 159 Church organ 1 | 227 Synthetic tonic 8 (bass plus tonic 1) |
| 024 Guitar (nylon) | 092 Synthetic voice 5 | 160 Reed organ 1 | 228 Synthetic voice 1 (new century 1) |
| 025 Guitar (steel string) | 093 Synthetic voice 6 (metallic sound) | 161 Accordion 1 | 229 Synthetic voice 2 (warm 1) |
| 026 Guitar (Jazz) | 094 Synthetic voice 7 (halo) | 162 Harmonica 1 | 230 Synthetic voice 3 (polysynth 1) |
| 027 Guitar (original) | 095 Synthetic voice 8 | 163 Tango accordion 1 | 231 Synthetic voice 4 (Chorus 1) |
| 028 Guitar (muffled) | 096 Synthetic effect 1 rain sound | 164 Guitar (nylon) 1 | 232 Synthetic voice 5 (bowed 1) |
| 029 Broken guitar | 097 Composite effect 2 track | 165 Guitar (steel string) 1 | 233 Synthetic voice 6 (metallic sound 1) |
| 030 Strong broken guitar | 098 Synthetic effect 3 crystal | 166 Guitar (Jazz) 1 | 234 Synthetic voice 7 (halo 1) |
| 031 Guitar Harmonics | 099 Synthetic effect 4 atmosphere | 167 Guitar (original) 1 | 235 Synthetic voice 8 (sweep1) |
| 032 Bass Cello (fingered) | 100 Synthetic effect 5 bright | 168 Guitar (muffled) 1 | 236 Synthetic effect 1 rain sound 1 |
| 033 Electric bass guitar (fingered) | 101 Synthetic effect 6 ghosts | 169 Broken guitar 1 | 237 Composite effect 2 track 1 |
| 034 Electric bass guitar (with paddle) | 102 Synthetic effect 7 echo | 170 Strong broken guitar 1 | 238 Synthetic effect 3 crystal 1 |
| 035 Wugebeishi | 103 Synthetic effect 8 science fiction | 171 Guitar overtone 1 | 239 Synthetic effect 4 atmosphere 1 |
| 036 Bass 1 (thumb tapping) | 104 Sita Qin | 172 Bass Cello (fingered) 1 | 240 Synthetic effect 5 bright 1 |
| 037 Bass 2 (thumb tapping) | 105 Turtledove Harp | 173 Electric bass guitar (fingering) 1 | 241 Synthetic effect 6: Ghost 1 |
| 038 Synthetic bass-1 | 106 Three stringed piano | 174 Electric bass guitar (with paddle) 1 | 242 Synthetic effect 7 echo 1 |
| 039 Synthetic bass-2 | 107 guzheng | 175 Wugebeishi 1 | 243 Synthetic effect 8 science fiction 1 |
| 040 violin | 108 Calimba | 176 Bass 3 (thumb tapping) | 244 Sitar 1 |
| 041 Viola | 109 bagpipe | 177 Bass 4 (thumb tapping) | 245 Turtledove 1 |
| 042 cello | 110 Ancient violin | 178 Synthetic bass-3 | 246 Three stringed Piano 1 |
| 043 Double bass | 111 Shanai | 179 Synthetic bass-4 | 247 Guzheng 1 |
| 044 Trill string | 112 Ringing tone | 180 Violin 1 | 248 Calimba 1 |
| 045 Pizzicato Strings | 113 Elder brother | 181 Viola 1 | 249 Bagpipes 1 |
| 046 Orchestral Harp | 114 Steel drum | 182 Cello 1 | 250 Viola 1 |
| 047 timpani | 115 Wooden fish | 183 Double bass 1 | 251 Sannaqin 1 |
| 048 String ensemble-1 | 116 osu | 184 Vibrato string 1 | 252 Ringtone 1 |
| 049 String ensemble-2 | 117 Melody Alto drum | 185 Plucked string 1 | 253 Brother 1 |
| 050 Synthetic string-1 | 118 Synthetic drum | 186 Orchestral harp 1 | 254 Steel drum 1 |
| 051 Synthetic string-2 | 119 Echo cymbal | 187 Timpani 1 | 255 Wooden fish 1 |
| 052 Church choral harmony | 120 Guitar string scraping noise | 188 String ensemble-3 | 256 Taigu 1 |
| 053 Vocal Harmony | 121 Play a breath sound | 189 String ensemble-4 | 257 Melody Alto drum 1 |
| 054 Synth Voice | 122 Wave sound | 190 Synthetic string-3 | 258 Synthetic drum 1 |
| 055 Orchestral ensemble | 123 Birdsong | 191 Synthetic string-4 | 259 Echo cymbal 1 |
| 056 trumpet | 124 Telephone ring | 192 Church choir harmony 1 | 260 Guitar string scraping noise 1 |
| 057 Trombone | 125 helicopter | 193 Vocal harmony 1 | 261 Play air tone 1 |
| 058 Tuba | 126 Applause | 194 Synthetic voice 1 | 262 Wave sound 1 |
| 059 Muffled horn | 127 shot | 195 Orchestra 1 | 263 Birdsong 1 |
| 060 French | 128 dulcimer | 196 Small 1 | 264 Telephone bell 1 |
| 061 Wind Ensemble | 129 Zheng | 197 Trombone 1 | 265 Helicopter 1 |
| 062 Synthetic wind-1 | 130 Zhongruan | 198 Bass 1 | 266 Applause 1 |
| 063 Synthetic guangle-2 | 131 Pipa | 199 Muffled horn 1 | 267 Gunshot 1 |
| 064 Treble Saxophone | 132 Big suona | 200 France 1 | 268 Dulcimer 1 |
| 065 Alto Saxophone | 133 Suona | 201 Wind Ensemble 1 | 269 Zheng 1 |
| 066 NO.2 Alto Saxophone | 134 erhu fiddle | 202 Synthetic guangle-3 | 270 Zhongruan 1 |
| 067 baritone saxophone | 135 Yuehu | 203 Synthetic guangle-4 | 271 Pipa 1 |

| | | | | | | | |
|-----|---------------------------------------|-----|---|-----|--------------------------------------|-----|---------------------------------------|
| 272 | Blg suona 1 | 340 | France 2 | 408 | Dulcimer 2 | 476 | Small 3 |
| 273 | Suona 1 | 341 | Wind Ensemble 2 | 409 | Zheng 2 | 477 | Trombone 3 |
| 274 | Erhu 1 | 342 | Synthetic guanie-5 | 410 | Zhongruan 2 | 478 | Bass 3 |
| 275 | Yuehu 1 | 343 | Synthetic guanie-6 | 411 | Pipa 2 | 479 | Muffled horn 3 |
| 276 | Flute 1 | 344 | Treble Saxophone 2 | 412 | Blg suona 2 | 480 | France 3 |
| 277 | Bang di 1 | 345 | Alto Saxophone 2 | 413 | Suona 2 | 481 | Wind Ensemble 3 |
| 278 | Guzheng 1 | 346 | NO.2 Alto Saxophone 2 | 414 | Erhu 2 | 482 | Synthetic wind-7 |
| 279 | Qudi 1 | 347 | Upper bass saxophone 2 | 415 | Yuehu 2 | 483 | Synthetic wind-8 |
| 280 | Acoustic grand piano 2 | 348 | Oboe 2 | 416 | Flute 2 | 484 | Treble Saxophone 3 |
| 281 | Bright piano 2 | 349 | British tube 2 | 417 | Bang di 2 | 485 | Alto Saxophone 3 |
| 282 | TVU piano 2 | 350 | Bassoon tube 2 | 418 | Guzheng 2 | 486 | Saxophone 3 Alto |
| 283 | Bar piano 2 | 351 | Clarinet 2 | 419 | Qudi 2 | 487 | Upper bass saxophone 3 |
| 284 | Electric piano 1-2 | 352 | Piccolo 2 | 420 | Acoustic grand piano 3 | 488 | Oboe 3 |
| 285 | Electric piano 2-2 | 353 | Flute 2 | 421 | Bright piano 3 | 489 | British tube 3 |
| 286 | Harpichord 2 | 354 | Wooden flute 2 | 422 | TVU piano 3 | 490 | Bassoon tube 3 |
| 287 | Clavichord 2 | 355 | Paidi 2 | 423 | Bar piano 3 | 491 | Clarinet 3 |
| 288 | Pianist 2 | 356 | Bottle blowing sound 2 | 424 | Electric piano 1-3 | 492 | Piccolo 3 |
| 289 | Zhong Qin 2 | 357 | Chiba (Japanese musical instrument 2) | 425 | Electric piano 2-3 | 493 | Flute 3 |
| 290 | Music box 2 | 358 | Whistle 2 | 426 | Harpichord 3 | 494 | Wooden flute 3 |
| 291 | Vibrating harp 2 | 359 | Ocarina 2 | 427 | Clavichord 3 | 495 | Paidi 3 |
| 292 | Marimba 2 | 360 | Synthetic tonic 1 (square wave 2) | 428 | Steel piano 3 | 496 | Bottle blowing sound 3 |
| 293 | Xylophone 2 | 361 | Synthetic tonic 2 (sawtooth wave 2) | 429 | Zhong Qin 3 | 497 | Chiba (Japanese musical instrument 3) |
| 294 | Guan Zhongdin 2 | 362 | Composite lead 3 | 430 | Music box 3 | 498 | Whistle 3 |
| 295 | Desima Qin 2 | 363 | Synthetic tonic 4 (chip lead 2) | 431 | Vibrating harp 3 | 499 | Ocarina 3 |
| 296 | Electric organ 2 | 364 | Synthetic tonic 5 (charang 2) | 432 | Marimba 3 | 500 | Synthetic tonic 1 (square wave 3) |
| 297 | Percussion organ 2 | 365 | Synthetic tonic 6 (vocal 2) | 433 | Xylophone 3 | 501 | Synthetic tonic 2 (sawtooth wave 3) |
| 298 | Rock organ 2 | 366 | Synthetic tonic 7 (parallel pentameter 2) | 434 | Guan Zhongdin 3 | 502 | Call lead 3 |
| 299 | Church organ 2 | 367 | Synthetic tonic 8 (bass plus tonic 2) | 435 | Desima Qin 3 | 503 | Synthetic tonic 4 (chip lead 3) |
| 300 | Reed organ 2 | 368 | Synthetic voice 1 (New Century 2) | 436 | Electric organ 3 | 504 | Synthetic tonic 5 (charang 3) |
| 301 | Accordion 2 | 369 | Synthetic voice 2 (warm 2) | 437 | Percussion organ 3 | 505 | Synthetic tonic 6 (vocal 3) |
| 302 | Harmonica 2 | 370 | Synthetic voice 3 (polysynth 2) | 438 | Rock organ 3 | 506 | Synthetic tonic 7 (parallel pentad 3) |
| 303 | Tango accordion 2 | 371 | Synthetic voice 4 (Chorus 2) | 439 | Church organ 3 | 507 | Synthetic tonic 8 (bass plus tonic 3) |
| 304 | Guitar (nylon) 2 | 372 | Synthetic voice 5 (bowed 2) | 440 | Reed organ 3 | 508 | Synthetic voice 1 (new century 3) |
| 305 | Guitar (steel string) 2 | 373 | Synthetic voice 6 (metallic sound 2) | 441 | Accordion 3 | 509 | Synthetic voice 2 (warm 3) |
| 306 | Guitar (Jazz) 2 | 374 | Synthetic voice 7 (Halo 2) | 442 | Harmonica 3 | 510 | Polyphony 3 |
| 307 | Guitar (original) 2 | 375 | Synthetic voice 8 (sweep2) | 443 | Tango accordion 3 | 511 | Synthetic voice 4 (Chorus 3) |
| 308 | Guitar (muffled) 2 | 376 | Synthetic effect 1 rain sound 2 | 444 | Guitar (nylon) 3 | 512 | Synthetic voice 5 (bowed 3) |
| 309 | Broken guitar 2 | 377 | Composite effect 2 track 2 | 445 | Guitar (steel string) 3 | 513 | Synthetic voice 6 (metallic sound 3) |
| 310 | Strong broken guitar 2 | 378 | Synthetic effect 3 crystal 2 | 446 | Guitar (Jazz) 3 | 514 | Synthetic voice 7 (Halo 3) |
| 311 | Guitar overtone 2 | 379 | Synthetic effect 4 atmosphere 2 | 447 | Guitar (original) 3 | 515 | Synthetic voice 8 (sweep3) |
| 312 | Bass Cello (fingered) 2 | 380 | Synthetic effect 5 bright 2 | 448 | Guitar (muffled) 3 | 516 | Synthetic effect 1 rain sound 3 |
| 313 | Electric bass guitar (fingering) 2 | 381 | Synthetic effect 6 ghost 2 | 449 | Broken guitar 3 | 517 | Composite effect 2 track 3 |
| 314 | Electric bass guitar (using paddle) 2 | 382 | Synthetic effect 7 echo 2 | 450 | Strong broken guitar 3 | 518 | Synthetic effect 3 crystal 3 |
| 315 | Wugebelshi 2 | 383 | Synthetic effect 8 science fiction 2 | 451 | Guitar overtone 3 | 519 | Synthetic effect 4 atmosphere 3 |
| 316 | Bass 5 (thumb tapping) | 384 | Sitar 2 | 452 | Bass Cello (fingered) 3 | 520 | Synthetic effect 5 bright 3 |
| 317 | Bass 6 (thumb tapping) | 385 | Turtledove 2 | 453 | Electric bass guitar (fingering) 3 | 521 | Synthetic effect 6 ghost 3 |
| 318 | Synthetic bass-5 | 386 | Three stringed piano 2 | 454 | Electric bass guitar (with paddle) 3 | 522 | Synthetic effect 7 echo 3 |
| 319 | Synthetic bass-6 | 387 | Guzheng 2 | 455 | Wugebelshi 3 | 523 | Synthetic effect 8.3 |
| 320 | Violin 2 | 388 | Calimba 2 | 456 | Bass 7 (thumb tapping) | 524 | Sitar 3 |
| 321 | Viola 2 | 389 | Bagpipes 2 | 457 | Bass 8 (thumb tapping) | 525 | Turtledove harp 3 |
| 322 | Cello 2 | 390 | Viola 2 | 458 | Synthetic bass-7 | 526 | Three stringed piano 3 |
| 323 | Double Bass 2 | 391 | Sannaoin 2 | 459 | Synthetic bass-8 | 527 | Guzheng 3 |
| 324 | Vibrato string 2 | 392 | Ringtone 2 | 460 | Violin 3 | 528 | Calimba 3 |
| 325 | Plucked string 2 | 393 | Brother 2 | 461 | Viola 3 | 529 | Bagpipes 3 |
| 326 | Orchestral harp 2 | 394 | Steel drum 2 | 462 | Cello 3 | 530 | Viola 3 |
| 327 | Timpani 2 | 395 | Wooden fish 2 | 463 | Double bass 3 | 531 | Sannaoin 3 |
| 328 | String ensemble-5 | 396 | Taigu 2 | 464 | Trill string 3 | 532 | Ringtone 3 |
| 329 | String ensemble-6 | 397 | Melody Alto drum 2 | 465 | Plucked string 3 | 533 | Brother 3 |
| 330 | Synthetic string-5 | 398 | Synthetic drum 2 | 466 | Orchestral harp 3 | 534 | Steel drum 3 |
| 331 | Synthetic string-6 | 399 | Echo cymbal 2 | 467 | Timpani 3 | 535 | Wooden fish 3 |
| 332 | Church choir harmony 2 | 400 | Guitar string scraping noise 2 | 468 | String ensemble-7 | 536 | Taigu 3 |
| 333 | Vocal harmony 2 | 401 | Play air tone 2 | 469 | String ensemble-8 | 537 | Melody Alto drum 3 |
| 334 | Synthetic voice 2 | 402 | Wave sound 2 | 470 | Synthetic string-7 | 538 | Synthetic drum 3 |
| 335 | Orchestra 2 | 403 | Birdsong 2 | 471 | Synthetic string-8 | 539 | Echo cymbal 3 |
| 336 | Small 2 | 404 | Telephone bell 2 | 472 | Church choir harmony 3 | 540 | Guitar string scraping noise 3 |
| 337 | Trombone 2 | 405 | Helicopter 2 | 473 | Vocal harmony 3 | 541 | Play air 3 |
| 338 | Bass 2 | 406 | Applause 2 | 474 | Synthetic voice 3 | 542 | Wave sound 3 |
| 339 | Muffled horn 2 | 407 | Gunshot 2 | 475 | Orchestra 3 | 543 | Birdsong 3 |

| | |
|--|---|
| 544 Telephone ring 3 | 612 Church choir Harmony 4 |
| 545 Helicopter 3 | 613 Vocal Harmony 4 |
| 546 Applause 3 | 614 Synthetic voice 4 |
| 547 Gunshot 3 | 615 Orchestra 4 |
| 548 Dulcimer 3 | 616 Small 4 |
| 549 Zheng 3 | 617 Trombone 4 |
| 550 Zhongruan 3 | 618 Bass 4 |
| 551 Pipa 3 | 619 Muffled horn 4 |
| 552 Suona 3 | 620 France 4 |
| 553 Suona 3 | 621 Wind Ensemble 4 |
| 554 Erhu 3 | 622 Synthetic wind-9 |
| 555 Yuehu 3 | 623 Synthetic wind-10 |
| 556 Flute 3 | 624 Treble Saxophone 4 |
| 557 Bang Di 3 | 625 NO.2 Alto Saxophone 4 |
| 558 Guzheng 3 | 626 Alto Saxophone 4 |
| 559 Qudi 3 | 627 Upper bass saxophone 4 |
| 560 Acoustic grand piano 4 | 628 Oboe 4 |
| 561 Bright piano 4 | 629 British tube 4 |
| 562 TVU piano 4 | 630 Bassoon tube 4 |
| 563 Bar piano 4 | 631 Clarinet 4 |
| 564 Electric piano 1-4 | 632 Piccolo 4 |
| 565 Electric piano 2-4 | 633 Flute 4 |
| 566 Harpsichord 4 | 634 Wooden flute 4 |
| 567 Clavichord 4 | 635 Pald 4 |
| 568 Pianist 4 | 636 Bottle blowing 4 |
| 569 Zhong Qin 4 | 637 Chiba (Japanese musical instrument 4) |
| 570 Music box 4 | 638 Whistle 4 |
| 571 Vibrating harp 4 | 639 Ocarina 4 |
| 572 Marimba 4 | 640 Synthetic tonic 1 (square wave 4) |
| 573 Xylophone 4 | 641 Synthetic tonic 2 (sawtooth wave 4) |
| 574 Guan Zhongqin 4 | 642 Call lead 4 |
| 575 Desima Qin 4 | 643 Chime lead 4 |
| 576 Electric organ 4 | 644 Synthetic tonic 5 (charang 4) |
| 577 Percussion organ 4 | 645 Synthetic tonic 6 (vocal 4) |
| 578 Rock organ 4 | 646 Synthetic tonic 7 (parallel pentad 4) |
| 579 Church organ 4 | 647 Synthetic tonic 8 (bass plus tonic 4) |
| 580 Reed organ 4 | 648 Synthetic voice 1 (new century 4) |
| 581 Accordion 4 | 649 Synthetic voice 2 (warm 4) |
| 582 Harmonica 4 | 650 Polyphony 4 |
| 583 Tango accordion 4 | 651 Synthetic voice 4 (Chorus 4) |
| 584 Guitar (nylon) 4 | 652 Synthetic voice 5 (bowed 4) |
| 585 Guitar (steel string) 4 | 653 Synthetic voice 6 (metallic sound 4) |
| 586 Guitar (Jazz) 4 | 654 Synthetic voice 7 (halo 4) |
| 587 Guitar (original) 4 | 655 Synthetic voice 8 (sweep4) |
| 588 Guitar (muffled) 4 | 656 Synthetic effect 1 rain sound 4 |
| 589 Broken guitar 4 | 657 Composite effect 2 track 4 |
| 590 Strong broken guitar 4 | 658 Synthetic effect 4 crystal 4 |
| 591 Guitar overtone 4 | 659 Synthetic effect 4 atmosphere 4 |
| 592 Bass Cello (fingered) 4 | 660 Synthetic effect 5 bright 4 |
| 593 Electric bass guitar (fingering) 4 | 661 Synthetic effect 6 ghosts 4 |
| 594 Electric bass guitar (with paddle) 4 | 662 Synthetic effect 7 echo 4 |
| 595 No Bess 4 | 663 Synthetic effect 8-4 |
| 596 Bass 9 (thumb tapping) | 664 Sitar 4 |
| 597 Bass 10 (thumb tapping) | 665 Turtledove 4 |
| 598 Synthetic bass-9 | 666 Sanxian 4 |
| 599 Synthetic bass-10 | 667 Guzheng 4 |
| 600 Violin 4 | 668 Calimba 4 |
| 601 Viola 4 | 669 Bagpipes 4 |
| 602 Cello 4 | 670 Viola 4 |
| 603 Double bass 4 | 671 Sannalqin 4 |
| 604 Vibrato string 4 | 672 Ringtone 4 |
| 605 Plucked string 4 | 673 A brother 4 |
| 606 Orchestral harp 4 | 674 Steel drum 4 |
| 607 Timpan4 | 675 Wooden fish 4 |
| 608 String ensemble-9 | 676 Talgu 4 |
| 609 String ensemble-10 | 677 Melody Alto drum 4 |
| 610 Synthetic string-9 | 678 Synthetic drum 4 |
| 611 Synthetic string-10 | 679 Echo cymbal 4 |

Rhythm table

| | | | | | | | |
|----|---------------------------|-----|--------------------|-----|----------------------------|-----|-------------------------|
| 0 | 16 shot Aros 1 | 86 | March 2 | 132 | 16 beat 1 | 198 | Middle East music 2 |
| 1 | 16 shot Aros 2 | 67 | March 3 | 133 | 16 beat 2 | 199 | New soul 2 |
| 2 | 16 beat ballads 1 | 68 | Merengue 1 | 134 | 16 beat 3 | 200 | Plana 2 |
| 3 | 16 beat ballads 2 | 69 | Merengue 2 | 135 | Rock music in the 1990s | 201 | Polka 4 |
| 4 | 16 beats 1 | 70 | Middle East music | 136 | Modern pop music | 202 | Polka 5 |
| 5 | 16 beats 2 | 71 | New soul music | 137 | 8-beat ballad 2 | 203 | Polka 6 |
| 6 | 16 beats 3 | 72 | Plana | 138 | 8 beat slide Dance 2 | 204 | Classic pop 2 |
| 7 | Rock 'n' roll | 73 | Polka 1 | 139 | Acid rock 2 | 205 | Pop Dance 4 |
| 8 | 1980s pop music | 74 | Polka 2 | 140 | African music 2 | 206 | Pop dance music 5 |
| 9 | 8-beat ballad | 75 | Polka 3 | 141 | African pop 2 | 207 | Pop dance music 6 |
| 10 | 8-beat slide dance | 76 | Classic pop music | 142 | Bakata 4 | 208 | Popular Samba 4 |
| 11 | Acid rock | 77 | Pop dance music 1 | 143 | Bakata 5 | 209 | Popular Samba 5 |
| 12 | African music | 78 | Pop dance music 2 | 144 | Bakata 6 | 210 | Popular Samba 6 |
| 13 | African pop | 79 | Pop dance music 3 | 145 | Bao 2, Brazil | 211 | Reggae music 3 |
| 14 | Bakata 1 | 80 | Popular Samba 1 | 146 | Bijin Dance 2 | 212 | Reggae music 4 |
| 15 | Bakata 2 | 81 | Popular Samba 2 | 147 | Big band 3 | 213 | Cuban rhythm 6 |
| 16 | Bakata 3 | 82 | Popular Samba 3 | 148 | Big band 4 | 214 | Cuban rhythm 7 |
| 17 | Bao, Brazil | 83 | Reggae Music 1 | 149 | Bruce 2 | 215 | Cuban rhythm 8 |
| 18 | Beguine | 84 | Reggae Music 2 | 150 | Orchid music 2 | 216 | Cuban rhythm 9 |
| 19 | Big band 1 | 85 | Cuban rhythm 1 | 151 | Bolero 2 | 217 | Cuban rhythm 10 |
| 20 | Big band 2 | 86 | Cuban Rhythm 2 | 152 | Posanova 6 | 218 | Salsa 2 |
| 21 | Bruce | 87 | Cuban rhythm 3 | 153 | Posanova 7 | 219 | Samba dance 3 |
| 22 | Orchid music | 88 | Cuban rhythm 4 | 154 | Posanova 8 | 220 | Samba dance 4 |
| 23 | Bolero | 89 | Cuban rhythm 5 | 155 | Posanova 9 | 221 | Slide Rock Dance 3 |
| 24 | Posanova 1 | 90 | Salsa Dance | 156 | Posanova 10 | 222 | Slide Rock Dance 4 |
| 25 | Posanova 2 | 91 | Samba dance 1 | 157 | Country dance 3 | 223 | Slow rock 3 |
| 26 | Posanova 3 | 92 | Samba dance 2 | 158 | Country dance 4 | 224 | Slow rock 4 |
| 27 | Posanova 4 | 93 | Slide Rock Dance 1 | 159 | CALIPSO 2 | 225 | Slow soul music 6 |
| 28 | Posanova 5 | 94 | Slide Rock Dance 2 | 160 | Chinese national music 4 | 226 | Slow soul music 7 |
| 29 | Country dance 1 | 95 | Slow rock 1 | 161 | Chinese national music 5 | 227 | Slow soul music 8 |
| 30 | Country dance 2 | 96 | Slow rock 2 | 162 | Chinese national music 6 | 228 | Slow soul music 9 |
| 31 | CALIPSO | 97 | Slow soul music 1 | 163 | Mini Jazz 3 | 229 | Slow soul music 10 |
| 32 | Chinese national music 1 | 98 | Slow soul music 2 | 164 | Mini Jazz 4 | 230 | Soul music 9 |
| 33 | Chinese national music 2 | 99 | Slow soul music 3 | 165 | European beat 2 | 231 | Soul music 10 |
| 34 | Chinese national music 3 | 100 | Slow soul music 4 | 166 | European Soul 2 | 232 | Soul music 11 |
| 35 | Mini Jazz 1 | 101 | Slow soul music 5 | 167 | Funk soul music 9 | 233 | Soul music 12 |
| 36 | Mini Jazz 2 | 102 | Soul music 1 | 168 | Funk soul music 10 | 234 | Soul music 13 |
| 37 | European beat | 103 | Soul music 2 | 169 | Funk soul music 11 | 235 | Happy soul 14 |
| 38 | European soul music | 104 | Soul music 3 | 170 | Funk soul 12 | 236 | Soul music 15 |
| 39 | Funk soul 1 | 105 | Soul music 4 | 171 | Funk soul music 13 | 237 | Soul music 16 |
| 40 | Funk Soul 2 | 106 | Soul music 5 | 172 | Funk soul 14 | 238 | Ghost step 2 |
| 41 | Funk soul music 3 | 107 | Soul music 6 | 173 | Funk soul 15 | 239 | Swing 7 |
| 42 | Funk soul 4 | 108 | Soul music 7 | 174 | Funk soul music 16 | 240 | Swing 8 |
| 43 | Funk soul 5 | 109 | Soul music 8 | 175 | Habanera 2 | 241 | Swing 9 |
| 44 | Funk soul music 6 | 110 | Ghost step | 176 | Multi element Rhythm 2 | 242 | Swing music 10 |
| 45 | Funk soul 7 | 111 | Swing 1 | 177 | Multi element rock music 2 | 243 | Swing 11 |
| 46 | Funk soul music 8 | 112 | Swing 2 | 178 | Haoshi electronic music 3 | 244 | Swing music 12 |
| 47 | Habanera | 113 | Swing 3 | 179 | Haoshi electronic music 4 | 245 | Swing Rhythm 2 |
| 48 | Multi element rhythm | 114 | Swing 4 | 180 | Jazz sambal | 246 | Tango 4 |
| 49 | Multi element rock music | 115 | Swing 5 | 181 | Jazz Waltz 4 | 247 | Tango 5 |
| 50 | Haoshi electronic music 1 | 116 | Swing 6 | 182 | Jazz Waltz 5 | 248 | Tango 6 |
| 51 | Haoshi electronic music 2 | 117 | Swing Rhythm | 183 | Jazz Waltz 6 | 249 | Thai Music 2 |
| 52 | Jazz sambal | 118 | Tango 1 | 184 | Jorbo 2 | 250 | Twisted Jazz 2 |
| 53 | Jazz Waltz 1 | 119 | Tango 2 | 185 | Lambada Dance 2 | 251 | Waganado 2 |
| 54 | Jazz Waltz 2 | 120 | Tango 3 | 186 | Love song 6 | 252 | Waltz 5 |
| 55 | Jazz Waltz 3 | 121 | Thai music | 187 | Love song 7 | 253 | Waltz 6 |
| 56 | Jorbo dance | 122 | Twisted Jazz | 188 | Love song 8 | 254 | Waltz 7 |
| 57 | Lambada dance | 123 | Waganado | 189 | Love song 9 | 255 | Waltz 8 |
| 58 | Love song 1 | 124 | Waltz 1 | 190 | Love song 10 | 256 | 16 shot Yalei 5 |
| 59 | Love song 2 | 125 | Waltz 2 | 191 | Mambo 3 | 257 | 16 shot Yalei 6 |
| 60 | Love song 3 | 126 | Waltz 3 | 192 | Mambo 4 | 258 | 16 shot Yalei 7 |
| 61 | Love song 4 | 127 | Waltz 4 | 193 | March 4 | 259 | 16 shot Yalei 8 |
| 62 | Love song 5 | 128 | 16 shot Yalei 1 | 194 | March 5 | 260 | 16 beat 4 |
| 63 | Mambo 1 | 129 | 16 shot Yalei 2 | 195 | March 6 | 261 | 16 beat 5 |
| 64 | Mambo 2 | 130 | 16 shot Yalei 3 | 196 | Merengue 3 | 262 | 16 beat 6 |
| 65 | March 1 | 131 | 16 shot Yalei 4 | 197 | Merengue 4 | 263 | Rock music in the '91's |

Instrukcja obsługi / User Manual

| | | | | | | | |
|-----|----------------------------|-----|-------------------------|-----|----------------------------|-----|---------------------------|
| 264 | Modern pop music | 332 | Classic pop 3 | 410 | Posanova 18 | 478 | Slide rock dance 8 |
| 265 | 8-beat ballad 3 | 333 | Pop dance music 7 | 411 | Posanova 19 | 479 | Slow rock 7 |
| 266 | 8 beat slide Dance 3 | 334 | Pop dance music 8 | 412 | Posanova 20 | 480 | Slow rock 8 |
| 267 | Acid rock 3 | 335 | Pop dance music 9 | 413 | Country dance 7 | 481 | Slow soul music 16 |
| 268 | African music 3 | 336 | Popular Samba 7 | 414 | Country dance 8 | 482 | Slow soul music 17 |
| 269 | African pop 3 | 337 | Popular Samba 8 | 415 | CALIPSO 4 | 483 | Slow soul music 18 |
| 270 | Bakata 7 | 338 | Popular Samba 9 | 416 | Chinese national music 10 | 484 | Slow soul music 19 |
| 271 | Bakata 8 | 339 | Reggae music 5 | 417 | Chinese national music 11 | 485 | Slow soul music 20 |
| 272 | Bakata 9 | 340 | Reggae music 6 | 418 | Chinese national music 12 | 486 | Soul music 25 |
| 273 | Bao 3, Brazil | 341 | Cuban rhythm 11 | 419 | Mini Jazz 7 | 487 | Soul music 26 |
| 274 | Bijin Dance 3 | 342 | Cuban rhythm 12 | 420 | Mini Jazz 8 | 488 | Soul music 27 |
| 275 | Big band 5 | 343 | Cuban rhythm 13 | 421 | European beat 4 | 489 | Soul music 28 |
| 276 | Big band 6 | 344 | Cuban rhythm 14 | 422 | European soul 4 | 490 | Soul music 29 |
| 277 | Bruce 3 | 345 | Cuban rhythm 15 | 423 | Funk soul music 25 | 491 | Soul music 30 |
| 278 | Orchid music 3 | 346 | Salsa 3 | 424 | Funk soul music 26 | 492 | Soul music 31 |
| 279 | Bolero 3 | 347 | Samba dance 5 | 425 | Funk soul music 27 | 493 | Soul music 32 |
| 280 | Posanova 11 | 348 | Samba dance 6 | 426 | Funk soul music 28 | 494 | Ghost step 4 |
| 281 | Posanova 12 | 349 | Slide Rock Dance 5 | 427 | Funk soul music 29 | 495 | Swing 19 |
| 282 | Posanova 13 | 350 | Slide rock dance 6 | 428 | Funk soul music 30 | 496 | Swing music 20 |
| 283 | Posanova 14 | 351 | Slow rock 5 | 429 | Funk soul music 31 | 497 | Swing 21 |
| 284 | Posanova 15 | 352 | Slow rock 6 | 430 | Funk soul music 32 | 498 | Swing 22 |
| 285 | Country dance 5 | 353 | Slow soul music 11 | 431 | Habanera 4 | 499 | Swing music 23 |
| 286 | Country dance 6 | 354 | Slow soul music 12 | 432 | Multi element rhythm 4 | 500 | Swing 24 |
| 287 | CALIPSO 3 | 355 | Slow soul music 13 | 433 | Multi element rock music 4 | 501 | Swing rhythm 4 |
| 288 | Chinese national music 7 | 356 | Slow soul music 14 | 434 | Haoshi electronic music 7 | 502 | Tango 10 |
| 289 | Chinese national music 8 | 357 | Slow soul music 15 | 435 | Haoshi electronic music 8 | 503 | Tango 11 |
| 290 | Chinese national music 9 | 358 | Soul music 17 | 436 | Jazz sambal | 504 | Tango 12 |
| 291 | Mini Jazz 5 | 359 | Soul music 18 | 437 | Jazz Waltz 10 | 505 | Thai music 4 |
| 292 | Mini Jazz 6 | 360 | Soul music 19 | 438 | Jazz Waltz 11 | 506 | Twisted Jazz 4 |
| 293 | European beat 3 | 361 | Soul music 20 | 439 | Jazz Waltz 12 | 507 | Waganado 4 |
| 294 | European soul 3 | 362 | Soul music 21 | 440 | Jorbo 4 | 508 | Waltz 13 |
| 295 | Funk soul music 17 | 363 | Soul music 22 | 441 | Lambada Dance 4 | 509 | Waltz 14 |
| 296 | Funk soul 18 | 364 | Soul music 23 | 442 | Love song 16 | 510 | Waltz 15 |
| 297 | Funk soul music 19 | 365 | Soul music 24 | 443 | Love song 17 | 511 | Waltz 16 |
| 298 | Funk soul music 20 | 366 | Ghost step 3 | 444 | Love song 18 | 512 | 16 shot Yalei 9 |
| 299 | Funk soul music 21 | 367 | Swing 13 | 445 | Love song 19 | 513 | 16 shot Yalei 10 |
| 300 | Funk soul music 22 | 368 | Swing music 14 | 446 | Love song 20 | 514 | 16 shot Yalei 11 |
| 301 | Funk soul music 23 | 369 | Swing 15 | 447 | Mambo 7 | 515 | 16 shot Yalei 12 |
| 302 | Funk soul music 24 | 370 | Swing 16 | 448 | Mambo 8 | 516 | 16 beat 7 |
| 303 | Habanera 3 | 371 | Swing 17 | 449 | March 10 | 517 | 16 beat 8 |
| 304 | Multi element rhythm 3 | 372 | Swing 18 | 450 | March 11 | 518 | 16 beat 9 |
| 305 | Multi element rock music 3 | 373 | Swing rhythm 3 | 451 | March 12 | 519 | Rock music in the '92's |
| 306 | Haoshi electronic music 5 | 374 | Tango 7 | 452 | Merengue 7 | 520 | Modern pop music |
| 307 | Haoshi electronic music 6 | 375 | Tango 8 | 453 | Merengue 8 | 521 | 8-beat ballad 4 |
| 308 | Jazz sambal | 376 | Tango 9 | 454 | Middle East music 4 | 522 | 8 beat slide Dance 4 |
| 309 | Jazz Waltz 7 | 377 | Thai music 3 | 455 | New soul 4 | 523 | Acid rock 4 |
| 310 | Jazz Waltz 8 | 378 | Twisted Jazz 3 | 456 | Plana 4 | 524 | African music 4 |
| 311 | Jazz Waltz 9 | 379 | Waganado 3 | 457 | Polka 10 | 525 | African pop 4 |
| 312 | Jorbo 3 | 380 | Waltz 9 | 458 | Polka 11 | 526 | Bakata 10 |
| 313 | Lambada Dance 3 | 381 | Waltz 10 | 459 | Polka 12 | 527 | Bakata 11 |
| 314 | Love song 11 | 382 | Waltz 11 | 460 | Classic pop 4 | 528 | Bakata 12 |
| 315 | Love song 12 | 383 | Waltz 12 | 461 | Pop dance music 10 | 529 | Bao 4, Brazil |
| 316 | Love song 13 | 384 | 16 shot Yalei 9 | 462 | Pop dance music 11 | 530 | Bijin Dance 4 |
| 317 | Love song 14 | 385 | 16 shot Yalei 10 | 463 | Pop dance music 12 | 531 | Big band 7 |
| 318 | Love song 15 | 386 | 16 shot Yalei 11 | 464 | Popular Samba 10 | 532 | Big band 8 |
| 319 | Mambo 5 | 387 | 16 shot Yalei 12 | 465 | Popular Samba 11 | 533 | Bruce 4 |
| 320 | Mambo 6 | 388 | 16 beat 7 | 466 | Popular Samba 12 | 534 | Orchid music 4 |
| 321 | March 7 | 389 | 16 beat 8 | 467 | Reggae music 7 | 535 | Bolero 4 |
| 322 | March 8 | 390 | 16 beat 9 | 468 | Reggae music 8 | 536 | Posanova 16 |
| 323 | March 9 | 391 | Rock music in the '92's | 469 | Cuban rhythm 16 | 537 | Posanova 17 |
| 324 | Merengue 5 | 392 | Modern pop music | 470 | Cuban rhythm 17 | 538 | Posanova 18 |
| 325 | Merengue 6 | 393 | 8-beat ballad 4 | 471 | Cuban rhythm 18 | 539 | Posanova 19 |
| 326 | Middle East music 3 | 394 | 8 beat slide Dance 4 | 472 | Cuban rhythm 19 | 540 | Posanova 20 |
| 327 | New soul music 3 | 395 | Acid rock 4 | 473 | Cuban rhythm 20 | 541 | Country dance 7 |
| 328 | Plana 3 | 396 | African music 4 | 474 | Salsa 4 | 542 | Country dance 8 |
| 329 | Polka 7 | 397 | African pop 4 | 475 | Samba dance 7 | 543 | CALIPSO 4 |
| 330 | Polka 8 | 398 | Bakata 10 | 476 | Samba dance 8 | 544 | Chinese national music 10 |
| 331 | Polka 9 | 399 | Bakata 11 | 477 | Slide rock dance 7 | 545 | Chinese national music 11 |

| | | | | | | | |
|-----|-----------------------|-----|----------------------------|-----|---------------------|-----|--------------------|
| 546 | Chinese folk music 12 | 560 | Multi element rhythm 4 | 574 | Love song 20 | 588 | Classic pop 4 |
| 547 | Mini Jazz 7 | 561 | Multi element rock music 4 | 575 | Mambo 7 | 589 | Pop dance music 10 |
| 548 | Mini Jazz 8 | 562 | Haoshi electronic music 7 | 576 | Mambo 8 | 590 | Pop dance music 11 |
| 549 | European beat 4 | 563 | Haoshi electronic music 8 | 577 | March 10 | 591 | Pop dance music 12 |
| 550 | European soul 4 | 564 | Jazz sambal | 578 | March 11 | 592 | Popular Samba 10 |
| 551 | Funk soul music 25 | 565 | Jazz Waltz 10 | 579 | March 12 | 593 | Popular Samba 11 |
| 552 | Funk soul music 26 | 566 | Jazz Waltz 11 | 580 | Merengue 7 | 594 | Popular Samba 12 |
| 553 | Funk soul music 27 | 567 | Jazz Waltz 12 | 581 | Merengue 8 | 595 | Reggae music 7 |
| 554 | Funk soul music 28 | 568 | Jorbo 4 | 582 | Middle East music 4 | 596 | Reggae music 8 |
| 555 | Funk soul music 29 | 569 | Lambada Dance 4 | 583 | New soul 4 | 597 | Cuban rhythm 16 |
| 556 | Funk soul music 30 | 570 | Love song 16 | 584 | Plana 4 | 598 | Cuban rhythm 17 |
| 557 | Funk soul music 31 | 571 | Love song 17 | 585 | Polka 10 | 599 | Cuban rhythm 18 |
| 558 | Funk soul music 32 | 572 | Love song 18 | 586 | Polka 11 | | |
| 559 | Habanera 4 | 573 | Love song 19 | 587 | Polka 12 | | |

Demo track table

| | | | | | |
|-----|--|-----|----------------------------|-----|--------------------|
| 000 | horse racing | 032 | A prune of plum | 064 | Piano Sonata |
| 001 | Whip the horse and transport grain | 033 | Moon full West Building | 065 | The Blue Danube |
| 002 | Step by step | 034 | Goodbye, Dable Mountain | 066 | yearn |
| 003 | Taihu Lake Beauty | 035 | Happy Chinese year | 067 | Tea for two |
| 004 | Osmanthus blooming in August | 036 | Dreamland | 068 | Sleigh ride |
| 005 | The Moon Over a Fountain | 037 | Grandma's Penghu bend | 069 | Red Nosed Reindeer |
| 006 | Tathagata divine palm | 038 | lover | 070 | Santa goes to town |
| 007 | Dating In The Mongoloid Tent | 039 | I wish you peace | 071 | Dream |
| 008 | Yangming Chunxiao | 040 | Pacific Hotel | 072 | Clock of time |
| 009 | Jasmine Flower | 041 | The madness of 1900 | 073 | Humorous music |
| 010 | Beaming with Joy | 042 | Family Restaurant | 074 | The Happy Farmer |
| 011 | good days | 043 | Johnny surfing | 075 | Cannon |
| 012 | childhood | 044 | Sinbad hand | 076 | Waltz Waltz |
| 013 | Purple bamboo tune | 045 | New paradise | 077 | Green sleeves |
| 014 | Auspicious three treasures | 046 | Happy birthday] | 078 | Polka |
| 015 | Love And Passion | 047 | Carmen Entr'acte | 079 | ARABESK |
| 016 | In that distant place | 048 | Short song | | |
| 017 | Song of grassland | 049 | jingle bells | | |
| 018 | Often go home and have a look | 050 | Christmas Eve | | |
| 019 | On the way to the market | 051 | oh Santa Claus | | |
| 020 | Original Extended Remix | 052 | Holy March | | |
| 021 | Qinghai Tibet Plateau | 053 | Oh! Susanna | | |
| 022 | Same song | 054 | Moon River | | |
| 023 | Eighteen bends of mountain road | 055 | ABC letter song | | |
| 024 | Send off | 056 | Merry Christmas to you | | |
| 025 | DJRainman Remix | 057 | Six ducklings | | |
| 026 | Where peach blossoms are in full bloom | 058 | Mary has a little sheep | | |
| 027 | Entering a new era | 059 | Moonlight Bay | | |
| 028 | Give me a red rose | 060 | U.S.A | | |
| 029 | Kangding Love Song | 061 | Crazy weapon | | |
| 030 | Hot Blooded | 062 | Before the next tear drops | | |
| 031 | Beijing tune | 063 | Doggie Waltz | | |

Information about used electrical and electronic equipment

The main goal of European and national law regulations is to reduce the amount of waste produced from used electrical and electronic equipment, to ensure an appropriate level of collection, recovery and recycling of used equipment, and to increase public awareness of its harmfulness to the environment, at each stage of use of electrical and electronic equipment. Therefore, it should be pointed out that households play a key role in contributing to reuse and recovery, including recycling of used equipment. The user of electrical and electronic equipment – intended for households – is obliged to return it to authorized collector after its use. However, it should be remembered that products classified as electrical or electronic equipment should be disposed of at authorized collection points.